



To: Planning and Zoning Commission
From: City Staff
Date: June 20, 2017
Re: **Case #17020 Modify Traffic Flow Pattern on Municipal Circle**

GENERAL INFORMATION

**Applicant/
Property Owner:** City of Raymore
100 Municipal Circle
Raymore, MO 64083

Requested Action: To modify the traffic flow and parking pattern of Municipal Circle

Property Location:



Advertisement: June 1, 2017 **Journal** newspaper
June 8, 2017 **Journal** newspaper

Public Hearing: June 20, 2017 Planning and Zoning Commission

Items of Record: **Exhibit 1. Mailed Notices to Adjoining Property Owners**
Exhibit 2. Notice of Publication
Exhibit 3. Unified Development Code
Exhibit 4. Application
Exhibit 5. Growth Management Plan
Exhibit 6. Staff Report

Additional exhibits as presented during hearing

REQUEST

Applicant is requesting to modify the existing two-way traffic pattern on Municipal Circle to a counterclockwise one-way pattern and replace the on-street parallel parking spaces with angle parking spaces, increasing the total number of on-street parking spaces.

CODE REQUIREMENTS

Chapter 530.010: Procedures for Vacation and Other Street Changes

Section 530.010B2:

“No public street shall be vacated, narrowed, relocated, extended, removed, widened, accepted, acquired, changed in use, sold or leased until it has been submitted to and approved by the Planning Commission after a public hearing”.

The Community Development Director determined that the change of traffic pattern on Municipal Circle from two-way flow to a one-way flow, and the change from on-street parallel parking spaces to on-street angle parking spaces, is a change in use of the public street and requires a public hearing to be held and approval of the Planning Commission to be obtained.

PREVIOUS PLANNING ACTIONS ON OR NEAR THE PROPERTY

1. The Raymore Municipal Complex First Plat was approved on October 28, 2002. Municipal Circle was dedicated as a public street as part of the subdivision plat.

2. Municipal Circle has a fifty-foot (50') right-of-way..

GOOD NEIGHBOR INFORMATIONAL MEETING COMMENTS

Although not required under City Code for this type of request, a Good Neighbor meeting was held on May 3, 2017. Two property owners surrounding Municipal Circle attended, and had the following questions:

Neighbor: Will all of the roads surrounding Municipal Circle be resurfaced?

Staff: Municipal Circle, Broadmoor Drive, and the north and south parking lots of City Hall will be micro surfaced. Skyline Drive was resurfaced in the Fall of 2016 as part of the 58 Highway Overlay project.

Neighbor: Will the on-street parking spaces be accessible for all tenants of Municipal Circle?

Staff: Yes, the development criteria for Municipal Center requires that “all parking spaces shall be available to all building employees, patrons, and visitors within the premises of the Municipal Center”.

STAFF COMMENTS

1. Municipal Circle is the public street that provides frontage for 9 lots within the Municipal Complex plat.
2. The UDC establishes the following parking space dimension requirements:

Dimensions

Off-street parking areas must comply with the following standards:

Dimensions (in feet)	Parking Angle			
	0° (parallel)	45°	60°	90°
Minimum space width	9	9	9	9
Minimum space length	18	18	18	18
Minimum one-way aisle width	18	13	18	18
Minimum two-way aisle width	24	24	24	24

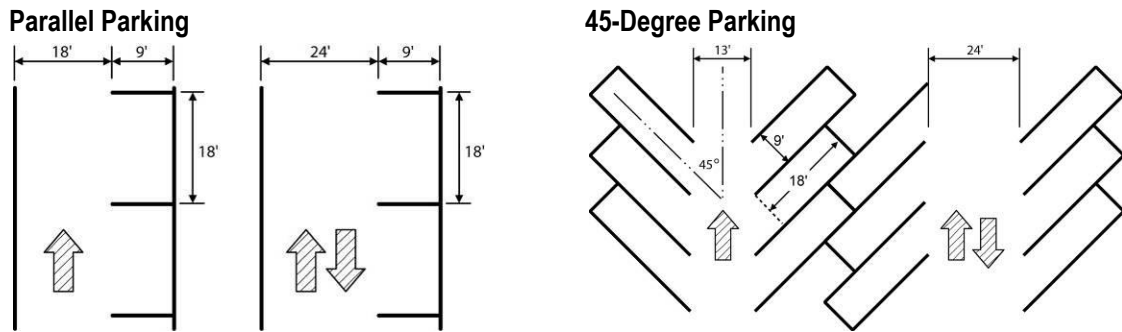

The angle parking spaces proposed for Municipal Complex will need to comply with the above standards. In addition, ADA spaces shall be provided as required.

3. The paved portion of Municipal Circle accommodates two-way traffic flow with a marked lane for parallel parking. Parking spaces are not specifically marked on the street pavement, but there is room for approximately 60 vehicles to parallel park on the street.



(aerial photograph of parking area along north side of Municipal Circle)

4. Modification to a one-way traffic flow pattern and angle parking spaces will provide approximately 90 parking spaces.
5. The City Center Overlay District allows for shared parking within the Municipal Complex. Every parking space on private property is available to be shared with any other property in the complex.

- A new access drive connection to the southeast corner of the parking lot immediately south of City Hall will be added to aid police vehicles in exiting the parking area and navigating the one-way Municipal Circle.

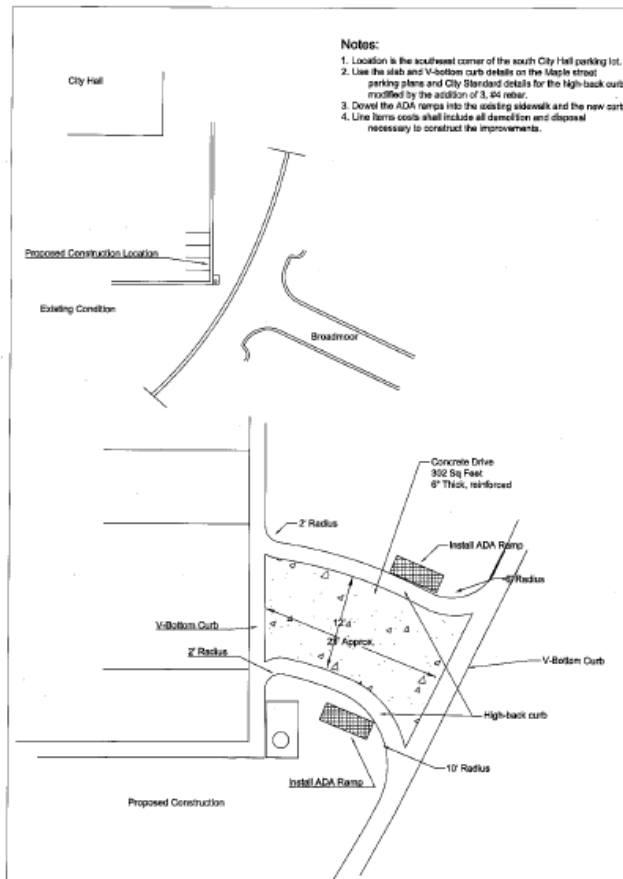

REVIEW OF INFORMATION AND SCHEDULE

Action	Planning Commission	City Council 1 st	City Council 2 nd
Public Hearing	June 20, 2017	n/a	n/a

STAFF RECOMMENDATION

The change from a two-way traffic flow pattern to a one-way pattern with angle parking spaces helps to establish the vision of the Municipal Complex area as a pedestrian friendly environment. With the addition of Centerview the use of the Municipal Complex area for community and special events will increase and the need for additional parking areas will increase. The proposed change will add approximately 30 parking spaces to the area.

City Staff recommends the Planning and Zoning Commission approve the request to modify the existing two-way traffic pattern on Municipal Circle to a counterclockwise one-way pattern and replace the on-street parallel parking spaces with angle parking spaces.