

**CITY OF RAYMORE**

100 Municipal Circle · Raymore, MO. 64083  
Phone · 816-892-3045 · Fax · 816-892-3093



**ADDENDUM NO. 3**

Ward Road Project  
Project #22-360-201

All plan holders are hereby notified and agree by signature below, that the proposal includes consideration of the following changes, amendments, and/or clarifications and costs associated with these changes and are included in the proposal.

**Addendum No. 3 - Clarification.**

- 1. Cass County Public Water Supply District #3 Addendum 1 - See Attached.

Any other questions regarding this proposal shall be submitted to Kim Quade, CPPB by email at [kquade@raymore.com](mailto:kquade@raymore.com) or by phone at (816) 892-3045. There will be no questions allowed after January 14, 2022 at 5 p.m.

I hereby certify that the above have been considered and associated costs have been included in this bid.

Company Name: \_\_\_\_\_

By: \_\_\_\_\_

Title: \_\_\_\_\_

Address: \_\_\_\_\_

City, State, Zip: \_\_\_\_\_

Date: \_\_\_\_\_ Phone: \_\_\_\_\_

Signature of Bidder: \_\_\_\_\_

**ADDENDUM MUST BE SUBMITTED WITH BID**

Cass County  
Public Water Supply District #3

Addendum 1

## SPECIFICATIONS

1. Replace bid items with the enclosed bid tab.
2. Section 01 200 00 – Measurement and Payments:  
Add Paragraph 3.02.H.3 – Long Service Reconnections  
Payment for service reconnections shall include the cost of connecting the old service line to the new main by way of a brass service saddle, tap, service pipe (Type K copper). New service line (Type K copper) shall be ran from the new water main east under Ward Road and at a minimum to the east right-of-way where the connection to the old service line shall be made. This reconnection shall be made after potable water becomes available from the new main.

## PLANS

1. The following Service Reconnections shall be Long Service Reconnections:
  - a. Sheet 9 – Approximate Station 35+30
  - b. Sheet 9 – Approximate Station 38+40
  - c. Sheet 13 – Approximate Station 57+40
  - d. Sheet 14 – Approximate Station 60+18
  - e. Sheet 16 – Approximate Station 67+42The following is a new Long Service Reconnection:
  - a. Sheet 15 – Approximate Station 65+00 (New)
2. Clarification:
  - a. The Note *MJ Plug Valve* at Stations 57+00 and 58+75 are locations to install 8"x8"x8" tees with an 8" gate valve and box on the branch. The gave valve shall be MJ plugged.
3. Clarification:
  - a. Connection F20 shall connect to existing waterline with an 8" solid sleeve.
4. Connection E20 shall be replaced with the enclosed connection detail and include a crossing of Ward Road as seen in detail.

# BID FORM FOR CONSTRUCTION CONTRACT

The terms used in this Bid with initial capital letters have the meanings stated in the Instructions to Bidders, the General Conditions, and the Supplementary Conditions.

## ARTICLE 1—OWNER AND BIDDER

1.01 This Bid is submitted to:

- A. **PWSD No. 3, Cass County, MO**  
**730 N Ward Road**  
**Raymore, MO 64083**  
**Ward Road Waterline Replacement**  
**Project No. 0321052.01**

1.02 The undersigned Bidder proposes and agrees, if this Bid is accepted, to enter into an Agreement with Owner in the form included in the Bidding Documents to perform all Work as specified or indicated in the Bidding Documents for the prices and within the times indicated in this Bid and in accordance with the other terms and conditions of the Bidding Documents.

## ARTICLE 2—ATTACHMENTS TO THIS BID

2.01 The following documents are submitted with and made a condition of this Bid:

- A. Required Bid security;
- B. List of Proposed Subcontractors;
- C. List of Proposed Suppliers;
- D. Evidence of authority to do business in the state of the Project;
- E. Contractor’s license number as evidence of Bidder’s State Contractor’s License;
- F. Required Certification of Compliance with the requirements of the Domestic Products Procurement Law RSMo. 34.350.RSMo 34.359.

## ARTICLE 3—BASIS OF BID—LUMP SUM BID AND UNIT PRICES

3.01 *Unit Price Bids*

- A. Bidder will perform the following Work at the indicated unit prices:

| Item No. | Description                     | Unit | Estimated Quantity | Bid Unit Price | Bid Amount |
|----------|---------------------------------|------|--------------------|----------------|------------|
| 1        | 8" Restrained Joint, PVC, C-900 | LF   | 480                | \$             | \$         |
| 2        | 8" PVC C-900                    | LF   | 7231               | \$             | \$         |
| 3        | Locator Wire                    | LF   | 7911               | \$             | \$         |
| 4        | Alexander Creek Crossing        | LF   | 200                | \$             | \$         |
| 5        | Connection A20                  | LS   | 1                  | \$             | \$         |
| 6        | Connection B20                  | LS   | 1                  | \$             | \$         |
| 7        | Connection C20                  | LS   | 1                  | \$             | \$         |
| 8        | Connection D20                  | LS   | 1                  | \$             | \$         |
| 9        | Connection E20                  | LS   | 1                  | \$             | \$         |

|                                   |                                   |    |    |    |    |
|-----------------------------------|-----------------------------------|----|----|----|----|
| 10                                | Connection F20                    | LS | 1  | \$ | \$ |
| 11                                | Connection G20                    | LS | 1  | \$ | \$ |
| 12                                | Fire Hydrant                      | LS | 14 | \$ | \$ |
| 13                                | Service Reconnection              | EA | 20 | \$ | \$ |
| 14                                | E. Gore Road Crossing             | LS | 1  | \$ | \$ |
| 15                                | E. 166 <sup>th</sup> St. Crossing | LS | 1  | \$ | \$ |
| 16                                | Sierra Dr. Crossing               | LS | 1  | \$ | \$ |
| 17                                | Chateau Place Crossing            | LS | 1  | \$ | \$ |
| 18                                | Alexander Creek Drive Crossing    | LS | 1  | \$ | \$ |
| 19                                | 8" Gate Valve w/box               | EA | 2  | \$ | \$ |
| 20                                | Cut and Cap Existing Waterline    | LS | 2  | \$ | \$ |
| 21                                | Abandon Existing Valve            | EA | 12 | \$ | \$ |
| 22                                | Long Service Reconnection         | EA | 6  | \$ | \$ |
| Total of All Unit Price Bid Items |                                   |    |    |    | \$ |

B. Bidder acknowledges that:

1. each Bid Unit Price includes an amount considered by Bidder to be adequate to cover Contractor's overhead and profit for each separately identified item, and
2. estimated quantities are not guaranteed and are solely for the purpose of comparison of Bids, and final payment for all Unit Price Work will be based on actual quantities, determined as provided in the Contract Documents.

3.02 *Total Bid Price*

|  |    |
|--|----|
| Total Bid Price (Total of Unit Price Bids) | \$ |
|--|----|

**ARTICLE 4—TIME OF COMPLETION**

4.01 Bidder agrees that the Work will be substantially complete and will be completed and ready for final payment in accordance with Paragraph 15.06 of the General Conditions on or before the dates or within the number of calendar days indicated in the Agreement.

4.02 Bidder accepts the provisions of the Agreement as to liquidated damages.

**ARTICLE 5—BIDDER'S ACKNOWLEDGEMENTS: ACCEPTANCE PERIOD, INSTRUCTIONS, AND RECEIPT OF ADDENDA**

5.01 *Bid Acceptance Period*

A. This Bid will remain subject to acceptance for 60 days after the Bid opening, or for such longer period of time that Bidder may agree to in writing upon request of Owner.

5.02 *Instructions to Bidders*

A. Bidder accepts all of the terms and conditions of the Instructions to Bidders, including without limitation those dealing with the disposition of Bid security.

5.03 *Receipt of Addenda*

A. Bidder hereby acknowledges receipt of the following Addenda:

| Addendum Number | Addendum Date |
|-----------------|---------------|
|-----------------|---------------|

|  |  |
|--|--|
|  |  |
|  |  |
|  |  |

**ARTICLE 6—BIDDER’S REPRESENTATIONS AND CERTIFICATIONS**

6.01 *Bidder’s Representations*

- A. In submitting this Bid, Bidder represents the following:
1. Bidder has examined and carefully studied the Bidding Documents, including Addenda.
  2. Bidder has visited the Site, conducted a thorough visual examination of the Site and adjacent areas, and become familiar with the general, local, and Site conditions that may affect cost, progress, and performance of the Work.
  3. Bidder is familiar with all Laws and Regulations that may affect cost, progress, and performance of the Work.
  4. Bidder has carefully studied the reports of explorations and tests of subsurface conditions at or adjacent to the Site and the drawings of physical conditions relating to existing surface or subsurface structures at the Site that have been identified in the Supplementary Conditions, with respect to the Technical Data in such reports and drawings.
  5. Bidder has carefully studied the reports and drawings relating to Hazardous Environmental Conditions, if any, at or adjacent to the Site that have been identified in the Supplementary Conditions, with respect to Technical Data in such reports and drawings.
  6. Bidder has considered the information known to Bidder itself; information commonly known to contractors doing business in the locality of the Site; information and observations obtained from visits to the Site; the Bidding Documents; and the Technical Data identified in the Supplementary Conditions or by definition, with respect to the effect of such information, observations, and Technical Data on (a) the cost, progress, and performance of the Work; (b) the means, methods, techniques, sequences, and procedures of construction to be employed by Bidder, if selected as Contractor; and (c) Bidder’s (Contractor’s) safety precautions and programs.
  7. Based on the information and observations referred to in the preceding paragraph, Bidder agrees that no further examinations, investigations, explorations, tests, studies, or data are necessary for the performance of the Work at the Contract Price, within the Contract Times, and in accordance with the other terms and conditions of the Contract.
  8. Bidder is aware of the general nature of work to be performed by Owner and others at the Site that relates to the Work as indicated in the Bidding Documents.
  9. Bidder has given Engineer written notice of all conflicts, errors, ambiguities, or discrepancies that Bidder has discovered in the Bidding Documents, and of discrepancies between Site conditions and the Contract Documents, and the written resolution thereof by Engineer is acceptable to Contractor.
  10. The Bidding Documents are generally sufficient to indicate and convey understanding of all terms and conditions for performance and furnishing of the Work.

11. The submission of this Bid constitutes an incontrovertible representation by Bidder that without exception the Bid and all prices in the Bid are premised upon performing and furnishing the Work required by the Bidding Documents.

6.02 *Bidder's Certifications*

A. The Bidder certifies the following:

1. This Bid is genuine and not made in the interest of or on behalf of any undisclosed individual or entity and is not submitted in conformity with any collusive agreement or rules of any group, association, organization, or corporation.
2. Bidder has not directly or indirectly induced or solicited any other Bidder to submit a false or sham Bid.
3. Bidder has not solicited or induced any individual or entity to refrain from bidding.
4. Bidder has not engaged in corrupt, fraudulent, collusive, or coercive practices in competing for the Contract. For the purposes of this Paragraph 6.02.A:
  - a. Corrupt practice means the offering, giving, receiving, or soliciting of anything of value likely to influence the action of a public official in the bidding process.
  - b. Fraudulent practice means an intentional misrepresentation of facts made (a) to influence the bidding process to the detriment of Owner, (b) to establish bid prices at artificial non-competitive levels, or (c) to deprive Owner of the benefits of free and open competition.
  - c. Collusive practice means a scheme or arrangement between two or more Bidders, with or without the knowledge of Owner, a purpose of which is to establish bid prices at artificial, non-competitive levels.
  - d. Coercive practice means harming or threatening to harm, directly or indirectly, persons or their property to influence their participation in the bidding process or affect the execution of the Contract.

**ARTICLE 7—LIST OF SUBCONTRACTORS AND SUPPLIERS**

| <u>Name of Subcontractor or Supplier</u> | <u>Item of Work</u> |
|--|---------------------|
|  |                     |
|  |                     |
|  |                     |
|  |                     |
|  |                     |
|  |                     |
|  |                     |
|  |                     |
|  |                     |
|  |                     |
|  |                     |
|  |                     |
|  |                     |
|  |                     |
|  |                     |



BIDDER hereby submits this Bid as set forth above:

Bidder:

\_\_\_\_\_  
*(typed or printed name of organization)*

By: \_\_\_\_\_  
*(individual's signature)*

Name: \_\_\_\_\_  
*(typed or printed)*

Title: \_\_\_\_\_  
*(typed or printed)*

Date: \_\_\_\_\_  
*(typed or printed)*

*If Bidder is a corporation, a partnership, or a joint venture, attach evidence of authority to sign.*

Attest: \_\_\_\_\_  
*(individual's signature)*

Name: \_\_\_\_\_  
*(typed or printed)*

Title: \_\_\_\_\_  
*(typed or printed)*

Date: \_\_\_\_\_  
*(typed or printed)*

Address for giving notices:

\_\_\_\_\_  
\_\_\_\_\_

Bidder's Contact:

Name: \_\_\_\_\_  
*(typed or printed)*

Title: \_\_\_\_\_  
*(typed or printed)*

Phone: \_\_\_\_\_

Email: \_\_\_\_\_

Address: \_\_\_\_\_

\_\_\_\_\_  
\_\_\_\_\_  
\_\_\_\_\_

Bidder's Contractor License No.: (if applicable) \_\_\_\_\_

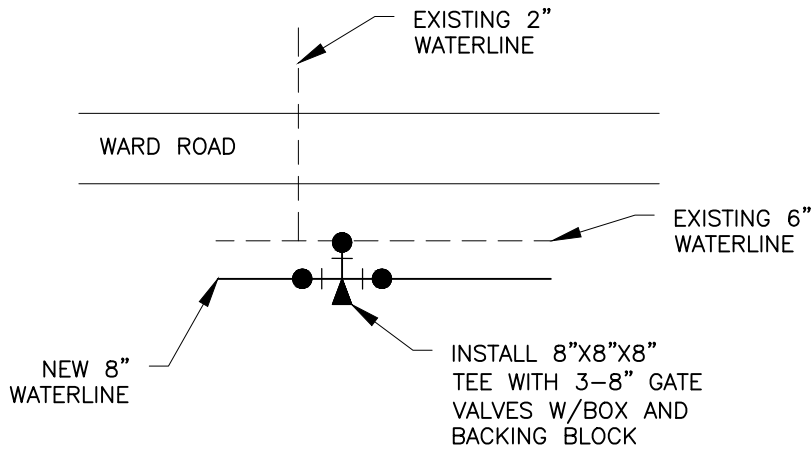

**TEMPORARY**  
**CONNECTION DETAIL**  
 Restrain Throughout

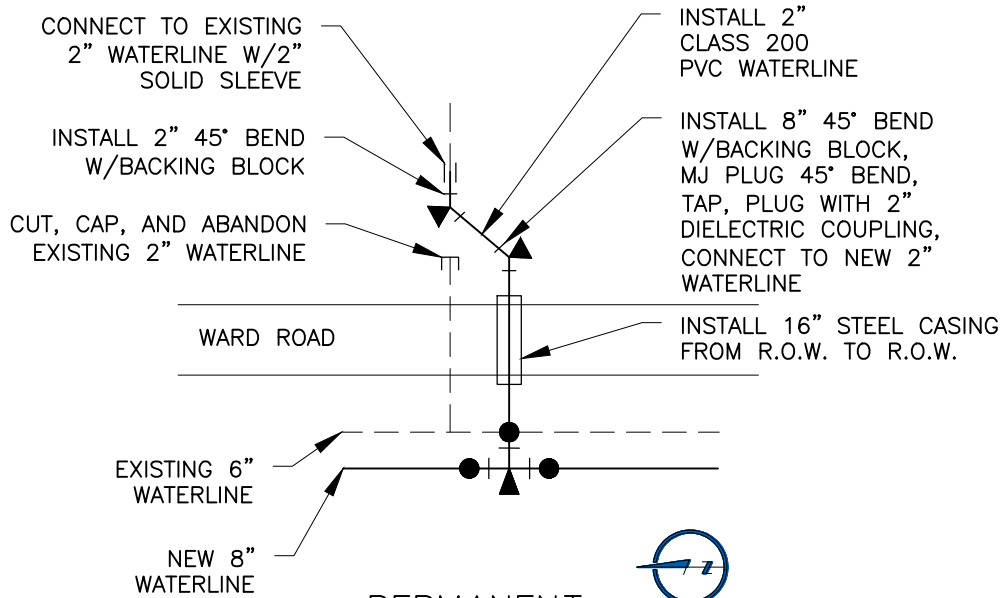

**PERMANENT**  
**CONNECTION DETAIL**  
 Restrain Throughout

L:\Engineering\0321052\_Cass\_3\_Ward\_Rd\_Waterline\_Replacement\Drawings\CONSTRUCTION DRAWINGS\0321052 - CONNECTION & STANDARD DETAILS.dwg, 1/6/2022 9:14:32 AM, SCOTT MORROW, LAMP RYNEARSON

**LAMP RYNEARSON**

LAMPRYNEARSON.COM

OMAHA, NEBRASKA  
 14710 W. DODGE RD, STE. 100 (402)496.2498  
 FORT COLLINS, COLORADO  
 4715 INNOVATION DR., STE. 100 (970)226.0342  
 KANSAS CITY, MISSOURI  
 9001 STATE LINE RD., STE. 200 (816)361.0440

DESIGNER / DRAFTER  
 CAH/SAM

REVIEWER

PROJECT NUMBER

0321052

DATE

01-06-2022

SURFACE LOCATION

BOOK AND PAGE

CONNECTION DETAILS

WARD ROAD WATERLINE RELOCATION

P.W.S.D. NO 3 CASS COUNTY MO

20A