



STANDARD CONTRACT DOCUMENTS

AND

TECHNICAL SPECIFICATIONS

FOR

UTILITY AND STREET CONSTRUCTION

September 2019

CITY OF RAYMORE, MISSOURI
100 Municipal Circle Raymore, Missouri 64083
816-331-1852 (Telephone) 816-331-8067 (Fax)

STANDARD CONTRACT DOCUMENTS AND TECHNICAL SPECIFICATIONS
FOR UTILITY AND STREET CONSTRUCTION

CITY OF RAYMORE, MISSOURI

TABLE OF CONTENTS (2019)

<u>SECTION</u>	<u>Standard Technical Specifications</u>
Table of Contents	Contract Documents
Advertisement for Bids	Contract Documents
Information for Bidders	Contract Documents
Bid Proposal Form	Contract Documents
Agreement	Contract Documents
Performance Bond	Contract Documents
Maintenance Bond	Contract Documents
Payment Bond	Contract Documents
Notice of Award	Contract Documents
Notice to Proceed	Contract Documents
General Conditions	Contract Documents
Sanitary Sewer Specifications	Sanitary Sewer
Standard Sanitary Details	Sanitary Sewer
Storm Sewer Specifications	Storm Sewer
Standard Storm Details	Storm Sewer
Water Specifications	Water
Standard Water Details	Water
Street Specifications	Street
Standard Street Details	Street

City of Raymore, Missouri
Street Specifications
Table of Contents

Article	Section Title	Page
1.00	GENERAL DESIGN CRITERIA	
2.00	MATERIALS	
3.00	INSTALLATION	
4.00	MATERIAL TESTS AND CERTIFICATIONS OF COMPLIANCE	
5.00	CONSTRUCTION METHODS FOR GRADING	

Street Specifications
ST-1
March 2017

1.00 GENERAL DESIGN STANDARDS

1.01 General

The design standards presented in this article are the minimum standards to be followed in the design and construction of the City of Raymore Public Streets. These minimum standards are not intended to be used as a substitute for actual construction specifications and design computations.

1.02 Pavement Design

The pavement sections shown on the following table may vary based on actual design calculations. **Suitable material (as per APWA section 2102.2.A.3.b.) for pavement subgrade is defined as entirely imperishable material with that portion passing the No. 40 sieve having a liquid limit not exceeding 40 and a plastic index not exceeding 25 when tested in accordance with ASTM D-423 and D-424, respectively.** Contractor shall submit test results to the City prior to installing curb and pavement. Subgrade material not meeting these limits shall be stabilized as per the recommendations of a qualified geotechnical laboratory and approved by the City. Testing and stabilization will be paid for by the Contractor.

Street Classification	Major Arterial	Minor Arterial	Collector	Residential	Industrial	Commercial	Rural
Pavement Width*	52 ft.	52 ft.	36-ft.	28-32 ft.	36 ft.	36-48 ft.	24 ft.

CONCRETE

Cross Slope	3%						
Thickness	9 in.	9 in.	7 in.	6 in.	9 in.	7 in.	N/A

ASPHALT

Cross Slope	3%						
Thickness	12 in.	11 in.	9 in.	8 in.	11 in.	9 in.	11 in.
Design Axle Loading	9 Ton	9 Ton	9 Ton	7 Ton	9 Ton	9 Ton	9 Ton
Traffic Class	IV	IV	III	II	IV	IV	IV
Design ESAL	1,100,000	1,100,000	110,000	27,000	1,100,000	1,100,000	1,100,000

* Back of curb to back of curb

1.03 Radius

1. Cul-De-Sac – Minimum radius for pavement on a cul-de-sac shall be thirty-nine feet to the back of the curb. When islands are constructed within the center of the cul-de-sac, the minimum radius shall be 39 feet plus the radius of the island.
2. Eyebrows – A 50-foot radius (39 feet to back of curb) eyebrow or bubble may be provided at the intersection of two streets. It is desirable that the centerline radius point be at the centerline intersection of the two streets, however, the centerline radius point may be offset a maximum of twenty-five feet toward the inside of the intersection on one of the incoming streets but not both. The said radius point may be offset toward the outside of the intersection until the eyebrow becomes a cul-de-sac and the intersection becomes a "T".

1.04 Temporary Cul-De-Sacs

When dead end streets over 300 feet are constructed or as directed by the City Engineer with plans for extensions in a future development phase and there are no provisions for a permanent turnaround, a temporary cul-de-sac shall be provided within the limits of Right-of-Way. The cul-de-sac shall consist of a 39-foot radius circle constructed of a minimum of a 4- inch asphalt base overlaid with a two- inch asphalt surface.

1.05 Grading Requirements and Geometric Design

1. Geometric Design:

Design should be based on the latest edition of AASHTO – following are the minimum design criteria:

Divided Arterials:

Minimum width dual roadways right-of-way		120 ft
Maximum gradient	6%	
Minimum sight distance on vertical curves (stop)		450 – 550 ft.
Minimum radii of horizontal curves		1200 ft.
Design speed		55 MPH

Arterials:

Single roadway right-of-way		80-100 ft
Maximum gradient	6%	
Minimum sight distance on vertical curves (stop)		325-400 ft.
Design speed		45 MPH
Standard Detail:		St - 1

Collectors:

Minimum width right-of-way	60 ft
Maximum gradient	8%
Minimum radii of horizontal curves	450 ft.
Minimum sight distance on vertical curves (stop)	225-250 ft.
Design Speed	35 MPH
Standard Detail	St - 2

Residential Streets:

Minimum width right-of-way	50 ft.
Maximum gradient	10%
Minimum radii of horizontal curves	200 ft.
Minimum sight distance of vertical curves (stop)	150 ft.
Design speed	25 MPH
Standard Detail	St - 3

Industrial Streets:

Minimum width right-of-way	60 ft.
Maximum gradient	6%
Minimum sight distance of vertical curves (stop)	200 ft.
Minimum radii of horizontal curves	300 ft.
Design speed	30 MPH

Commercial Streets:

Minimum width right-of-way	60 ft.
Maximum gradient	6%
Minimum radii of horizontal curves	300 ft.
Minimum sight distance on vertical curves (stop)	200 ft.
Design Speed	30 MPH
Standard Detail	St - 2

Rural Roads:

Minimum width right-of-way	40 ft.
Maximum gradient	6%
Minimum radii of horizontal curves	300 ft.
Minimum sight distance on vertical curves (stop)	200 ft.
Design speed	30 MPH
Standard Detail	St - 4

2. Minimum Gradient

The minimum gradient for all streets shall be 1.0%.

3. Maximum Gradient

The maximum gradient for streets may be exceeded only upon approval of the City Engineer in writing for unusual cases.

4. Tangent Length

The minimum tangent length between reverse curves shall be 50 feet for residential streets and 100 feet for all other classifications except no tangent will be required for radii longer than 500 feet.

5. Grading

Grading for paved areas shall consist of excavating, filling, and compacting earthwork within the limits of embankment fill and the cut section in accordance with these specifications and in conformity with the lines, grades, and typical cross section shown on the drawings as approved by the City Engineer. Subgrade shall be compacted under curbs.

6. Grading Behind Curbs

The finished grade shall slope from one-quarter inch vertical to one foot horizontal minimum to one-half inch vertical to one foot horizontal maximum above the back of the curbs. The grading gradients may be varied or exceeded upon approval of the City Engineer in writing, when grading calculations are submitted and approved by the City Engineer showing that the curb water carrying capacity is adequate and will not cause flooding of yards and basements.

1.06 New Streets Abutting Existing Streets

Sight distances for the abutting streets shall meet the requirements of AASHTO's policy on Geometric Design (latest edition). If these sight distance requirements cannot be met, the existing street shall be reconstructed at the Developer's expense to meet the design standards. Developer's Engineer will provide a certification on the applicable drawings that the AASHTO requirements have been met. Curb shall be installed to match future curb at ultimate design. Centerline of the street for ultimate design shall match centerline of existing street.

1.07 Private Streets

All privately owned streets shall be constructed in accordance with the provisions in this Article, i.e., General Design Standards, grading requirements and geometric design, horizontal and vertical alignment, pavement thickness, etc.

1.08 Superelevation

The design of street curves shall consider superelevation in accordance with the current AASHTO policy on Geometric Design of streets in order to establish the proper elevation between design speed and curvature.

1.09 Street Intersections

The intersection of streets shall be designed such that street crowns match at the center of the intersection.

Street swales to divert water across a street shall only be permitted on residential classification streets with the approval of the City Engineer. Flow of run-off water across streets shall be limited to one cubic foot per second.

When street swales are utilized, water shall not be diverted across the through street or if neither street is a through street, storm water shall be diverted across the street with the least traffic, as directed by the City Engineer.

1.10 Sidewalks

Sidewalk width is defined in the Unified Development Code. The sidewalk shall be a minimum of 4-feet behind the curb and within the public right of way. If a four foot separation between back of curb and sidewalk is not possible, the sidewalk shall be increased to six feet in width and shall be constructed abutting the back of the curb. Refer to "Section 2.00 "Materials", Section 3.00 "Installation". See Standard Detail St-5 for Handicapped Access Ramp design.

1.11 Guardrails

1. Location – At the locations required in the Roadside Design Guide published by AASHTO (latest edition).
2. Installation – Guardrail shall be installed according to the procedure outlined in the latest edition of the Missouri Standard Specifications for Highway Construction – Section 606.
3. Material – Guardrail material shall conform to the latest edition of the Missouri Standard Specifications for Highway Construction - Section 1040.

2.00 MATERIALS

2.01 Portland Cement Concrete Pavement

1. Concrete

KCMMB-4K

2. Portland Cement

ASTM C150, TYPE I or II

3. Coarse Aggregate	Per Approved Mix
4. Fine Aggregate	Per Approved Mix
5. Expansion Joint Material (1/2") with Peel	Flexible Foam Joint Filler Strip (or approved equal)
6. Joint Sealing Compound	ASTM 3405
7. Reinforcing Steel	ASTM A615
8. Welded Wire Fabric	ASTM A185
9. Curing Compound (equal)	ASTM C309 (or approved equal)
 2.02 Asphaltic Concrete Pavement	
1. Base Material 30%	APWA (Section 2205) Type I, Maximum Recycled Type I
2. Surface Coarse	APWA (Section 2205), Type III MSSHC (Section 403), Type B MSSHC (Section 403), Type C
3. Coarse Aggregate	APWA (Section 2205)
4. Fine Aggregate	APWA (Section 2205)
5. Asphalt Cement	APWA (Section 2205)
6. Track Coat (approved equal)	RC70, or SS-1 (or approved equal)
 2.03 Curb and Gutter	
1. Concrete	KCMMB-4K
2. Portland Cement	ASTM C-150, Type I or II
3. Coarse Aggregate	Per Approved Mix
4. Fine Aggregate	Per Approved Mix
5. Dimension Standard Details	St-6 thru St-8

- | | |
|------------------------------------|----------------|
| 6. Expansion Joint Material (1/2") | ASTM D1753 |
| 7. Joint Sealing Compound | ASTM 3405 |
| 8. Curing Compound | ASTM C309 |
| 9. Dowels | #5 Smooth Bars |

2.04 Driveway Entrances and Sidewalks

- | | |
|-----------------------|----------------------------------|
| 1. Concrete | KCMMB-4K |
| 2. Portland Cement | ASTM C150, Type I or II |
| 3. Coarse Aggregate | Per Approved Mix |
| 4. Fine Aggregate | Per Approved Mix |
| 5. Welded Wire Fabric | ASTM A185 |
| 6. Dimension
St-10 | Standard Details St-9 &
St-10 |

Copies of specifications listed above are available for review at the Public Works Department.

3.00 INSTALLATION

3.01 Portland Cement Concrete Pavement

Construction of Portland Cement Concrete Pavement shall conform to the requirements of APWA specifications Section 2208, Portland Cement Concrete Pavement, with the following modifications.

1. Forms – Horizontal and vertical alignment for all form work shall not vary more than one eighth inch in ten feet.
2. Reinforcing Steel – Reinforcing steel shall be for the shape and size shown on the accepted detail plans and when placed in the work shall be free from dirt, mill and rust scale, paint, oil, (except dowel bars), or other foreign substances. The arrangement and spacing of the bars shall be as shown on the approved drawings; all reinforcing steel shall be positively secured against displacement due to the placing of the concrete. Bars shall be bound firmly together with wire ties or metal clips where they cross or lap and shall be supported by metal supports, spacers, or metal hangers. Spliced bars shall lap not less than 40 times the nominal diameters of the bars spliced.

3. Reinforced Placement – Longitudinal joints shall be constructed with one half-inch diameter bars, 24"centers. Dowel bars shall be placed in expansion joints and in construction joints marking the end of the day's construction. Welded wire fabric reinforcement shall be placed two inches from the finished surface of the pavement.
4. Dowel bars- Dowel bars shall be smooth round bars placed as shown on the accepted drawings and shall be held in position exactly parallel to the surface and centerline of the slab by a metal device that is left in the pavement. This device shall hold each dowel in exactly the correct position so firmly that the dowels cannot be altered by concreting operations. The use of stones, brick or other bulk materials for supporting dowels or sleeves will not be permitted. One half of each bar shall be coated with basic sulphate blue lead or red lead paint with a heavy oil (not grease) to prevent bond. The painted and oiled end of the bar shall also be furnished with an approved paper or metal sleeve so designed as to provide a one-inch space at the end of the bar.

3.02 Asphaltic Concrete Pavement

Construction of Asphaltic Concrete Pavement shall be constructed in accordance with the requirements of APWA, Section 2200 "Paving" with the following modifications.

1. Base course shall be placed in lifts of three inches minimum and four inches maximum.
2. Tack coat between lifts shall consist of five hundredths to one-tenth gallons per square of RC-70 or SS-1 (or approved equal). A tack coat shall not be required between successive layers of base placed in the same working day.
3. Surface course shall be placed in two-inch maximum thickness lifts. Tack coat, if required in Item 2 above, shall consist of five hundredths to one-tenth gallon per square yard of RC-70 or SS-1 (or approved equal).

3.03 Curb and Gutter

1. Description – This work shall consist of air-entrained Portland Cement Concrete combined curb and gutter, constructed to the lines, grades, dimensions, and cross sections shown on the accepted drawings and in accordance with these specifications.
2. Curb Types:

- a. Curb and gutter for residential and collector streets shall be constructed in accordance with Standard Detail St-6, "Roll back curb and gutter", Type CG-2.
 - b. Curb and Gutter for Collectors, Divided Arterials, Arterials, Industrial, Commercial, Limited Access Collectors, and Frontage streets shall be constructed in accordance with Standard Detail St-7, "Straight back curb and gutter", Type CG-1.
3. Subgrade – The subgrade for combined curb and gutter shall be excavated to the grades and sections shown on the accepted drawings. The subgrade shall be of compacted density stipulated in this Article. Paving underneath curb (to 1' behind curb and gutter) is acceptable.
4. Forms – All forms shall be sufficiently strong and rigid and securely staked and braced to obtain a finished project correct to the dimensions, lines and grades required. Forms may be of steel or wood at the option of the contractor. All forms must be cleaned and oiled before each use.
5. Joints – Expansion, contraction, and construction joints shall be constructed at the intervals and places shown on the accepted drawings. Contraction joints shall be tooled or sawed. Sawed joints shall begin as soon as the concrete hardens sufficiently to prevent excessive raveling along the saw cut and shall finish before conditions induce uncontrolled cracks, regardless of the time or weather. All joints shall be of the type and materials shown on the accepted drawings. Minimum depth of contraction joints shall be one quarter (25%) of the overall concrete thickness.
6. Placing Concrete – Concrete for curb and gutter shall be placed upon the previously prepared, compacted and moistened subgrade. The concrete shall be compacted with an approved internal type vibrator, or by hand spudding and tamping. The surface shall be shaped by use of a steel tool to produce the section shown on the accepted drawings. The edges shall be rounded with edgers to form the radii indicated on the approved drawings. Curb placed with a curb machine shall produce the section shown on the accepted drawings.
7. Finish – The surface of curb and gutter shall be finished with a wooden or steel float and brushed. Excessive water used to bring 'mud' to the surface to ease finishing will be cause for rejection of the curb.
8. Curbing and Protection – Immediately after the finishing operation have been completed and as soon as marring of the concrete will not occur, the entire surface of the newly placed concrete shall be covered and cured in accordance with the following method. The concrete shall not be left exposed for more than one half hour between stages of curing or during the curing period.

- a. White Pigmented Membrane – After the free water has left the pavement surface, the entire surface shall be sealed by hand or machine spraying with a uniform application of white pigmented membrane curing material. The contractor shall use equipment to ensure uniform coverage of curing material, without loss, on the pavement at the rate of one gallon for each 150 square feet. If rain falls on the newly coated pavement before the film has dried sufficiently to resist damage, or if the film is damaged in any other way, the Contractor/Develop will be required to apply additional curing material to the affected portions. All areas cut by finishing tools subsequent to the application of the curing material shall immediately be given new applications at the rate specified above. If hair-checking develops before the membrane can be applied, the concrete shall be initially cured with wet burlap as specified in APWA, Section 2200 "Paving".
- b. Cold & Hot Weather Concrete – 'Cold' weather concrete shall conform to the requirements of MCIB Section 10 and 'hot' weather concrete shall conform to the requirements of MCIB Section 11.

3.04 Driveway Entrance and Sidewalks

Driveway entrances and sidewalks shall be constructed in accordance with APWA Specifications, Section 2208, with the following modifications.

1. All sidewalks shall be a minimum of four inches in depth, no reinforcing steel required. Concrete mix shall meet KCMMB-4k specifications.
2. All residential driveway approaches shall be a minimum of six inches thick, no reinforcing steel required. Concrete mix shall meet KCMMB-4k specifications. See detail ST-10.
3. All commercial/industrial driveway approaches shall be a minimum of eight inches thick, no reinforcing steel required. Concrete mix shall meet KCMMB-4k specifications. See detail ST-9.
4. Curbing shall be poured separately from the flatwork with no monolithic pours permitted.
5. A leveling course of compacted AB-3 shall be placed as a base material as required. All over excavated subgrade shall be completely filled with concrete, compacted AB-3 or suitable compacted backfill material.
6. In areas where commercial drives intersect with integral curbs, the curb shall be lowered to driveway elevations to provide for handicapped access.

7. 'Cold' weather concrete shall conform to the requirements of MCIB Section 10 and 'hot' weather concrete shall conform to the requirements of MCIB Section 11.
8. The top six inches of subgrade shall be compacted to 95 percent of maximum proctor density at optimum moisture content as determined by ASTM D698. Any unstable subgrade material, such as topsoil, shall be removed and replaced with suitable material and compacted as indicated above.

Any over-excavated subgrade shall be completely filled with concrete, backfilled with AB3, or backfilled with suitable material and compacted as indicated above.

3.05 Cleaning Operations

All catch basins, manholes, inlets and outlets and roadway surfaces shall be thoroughly cleaned of any accumulations of silt, debris, or foreign matter of any kind, and shall be free from such accumulations at the time of final inspection.

4.00 MATERIAL TESTS AND CERTIFICATIONS OF COMPLIANCE

4.01 Material Tests

When requested by the City Engineer, the contractor shall furnish testing and supply all test results at the contractor's expense and from an approved testing laboratory. Tests may be required for any of the following:

1. Standard Proctor tests for subgrade material.
2. Liquid Limit and Plastic Limit tests to determine the Plasticity Index of the Subgrade material.
3. Subgrade compaction on any section of the street and compaction around culverts, bridges, retaining walls, manholes, catch basins, and other locations inaccessible.
4. Aggregate for Portland Cement Concrete, Asphaltic Concrete Base and Asphaltic Concrete Surface.
5. A complete set of Test Property Curves for hot-mix design by Marshall Method for determining the optimum asphalt content for asphaltic concrete surface course and base for the current year. The curves shall have actual test values plotted and the number of test values determined shall be sufficient to establish a meaningful curve. Mix designs and Marshall test

results shall be submitted and approved by the City Engineer prior to construction.

6. Concrete compressive tests (cylinders), air entrainment, and slump.

5.00 CONSTRUCTION METHODS FOR GRADING

5.01 Finish Grading

Areas to be graded shall be cut or filled to within four hundredths of a foot of the approved subgrade elevations.

5.02 Excavating

All stable and suitable materials from excavation shall be used as far as practicable for fills as shown on the acceptable drawings. All unstable and unsuitable materials such as organic substances, soft clay, etc., shall be removed from the limits of the work. All tree stumps, masonry, and other obstructions shall be removed to a depth of four feet below the subgrade elevation. Where solid rock, shale, or similar material is found, the excavation shall be carried six inches below the subgrade for full width of the paved areas, plus an additional width for form work for curbs, catch basins, curb inlets, etc. The excavated area shall be backfilled to the subgrade and shoulder elevation with suitable earth or granular material and compacted.

5.03 Clearing and Grubbing

All sod shrubs, trees, and all vegetation and other deleterious material shall be removed from within the grading limits in cut or fill sections.

5.04 Fill

The embankment fill area shall be cleared and graded prior to placing of the fill layers. In no case shall boulders with a dimension greater than eight inches in any direction, or rock layers be deposited within two feet of subgrade elevation. Fill layer shall not exceed eight inches of compacted thickness.

5.05 Moisture Content

The moisture content of the soil at the time of compaction shall be uniform and shall be such that the soil can be compacted as specified. The moisture content shall not exceed minus one percent to plus three percent of the specified content.

5.06 Compaction in Fill Sections

After each fill layer has been spread as outlined in Paragraph 5.04, and brought to proper moisture content (5.05), the entire area shall be compacted as follows:

1. Compacted density of soil in each fill layer shall be equal to or greater than 95 percent of Standard Proctor Density within the moisture limits.
2. Sand and gravel which cannot be compacted satisfactorily with a sheepsfoot roll shall be rolled until no further consolidation is evident.

5.07 Compaction in Cut Sections

The soil six inches below the finish subgrade line in cut sections shall be scarified, broken up, adjusted to the proper moisture content and then compacted as specified above for fill sections. The depth of compaction in cut sections shall be six inches.

5.08 Utility Backfill

Backfill under pavements, driveways, sidewalks, and other paved areas shall be as follows:

1. Flowable fill shall be used for backfill in utility trenches, areas around culverts, bridges and retaining walls, curbs, manholes, and other sections that are inaccessible to the roller. Flowable fill mix design must be approved by the Engineer prior to placement. Backfill shall be placed as shown on Standard Detail St-11 (APWA p26 14)

Backfill in areas other than paved areas:

2. Backfill shall be finely divided, excavated material, free from debris, organic material, frozen material, and stones larger than six inches.

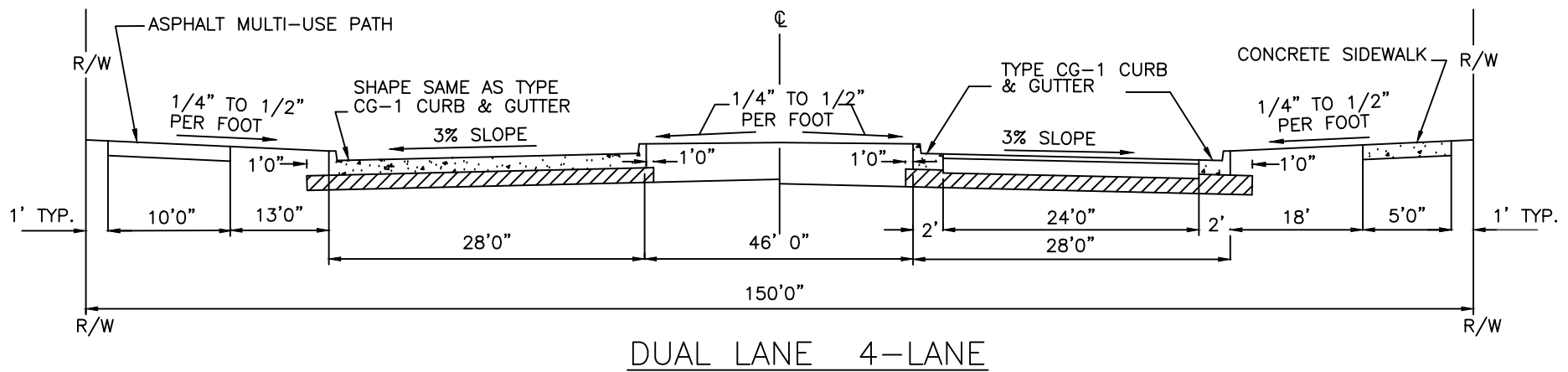

DUAL LANE 4-LANE

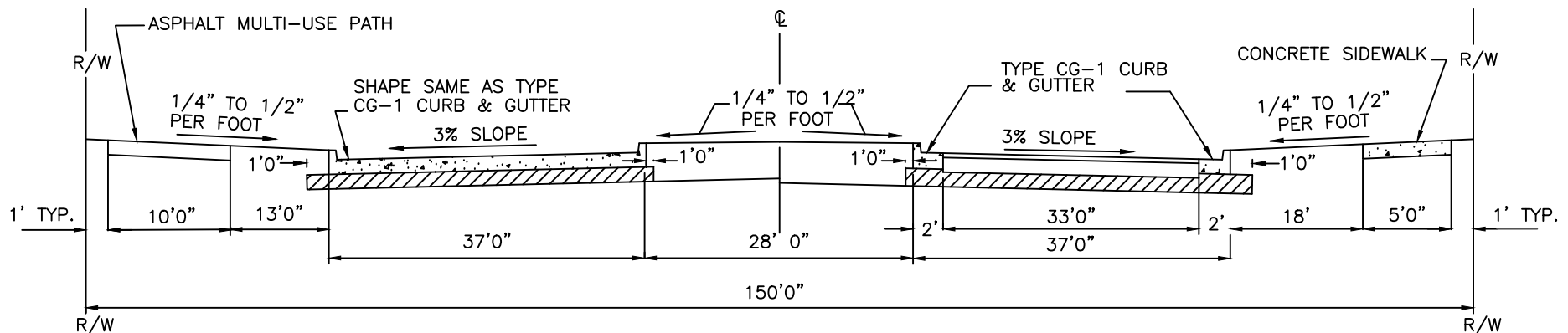



TRI LANE 3-LANE

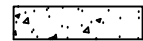

Notes:

1. All concrete shall be KCMMB 4K mix.
2. Type 2 Asphaltic Concrete is not allowed.
3. Engineer shall submit pavement designs if deviating from standard profiles shown above.
4. Asphalt Multi-Use Path:
 - Subgrade stabilized per Street Specifications section 1.02
 - 4" Type 1 Base Asphalt
 - 2" Type 3 or Type 5 Surface Asphalt

TYPE A CONSTRUCTION (Minimum Thickness)

-  9" Portland Cement Concrete Pavement
-  6" Compacted Subgrade Street Specification Section 1.02

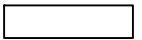
TYPE B CONSTRUCTION (Minimum Thickness)

-  2" Type 3 Asphaltic Concrete Surface
-  10" Type 1 Asphaltic Concrete Base
-  6" Compacted Subgrade Street Specification Section 1.02

PLANNING & ENGINEERING
 100 MUNICIPAL CIRCLE
 RAYMORE, MO 64083
 (816)331-0488

CITY OF RAYMORE

MAJOR ARTERIAL STREETS

DRAWN Modified 1/11/18	DATE
CHECKED	
APPROVED	

SIZE A	FSCM NO.	DWG NO. ST-1	REV
SCALE NONE	SHEET 1 OF 1		

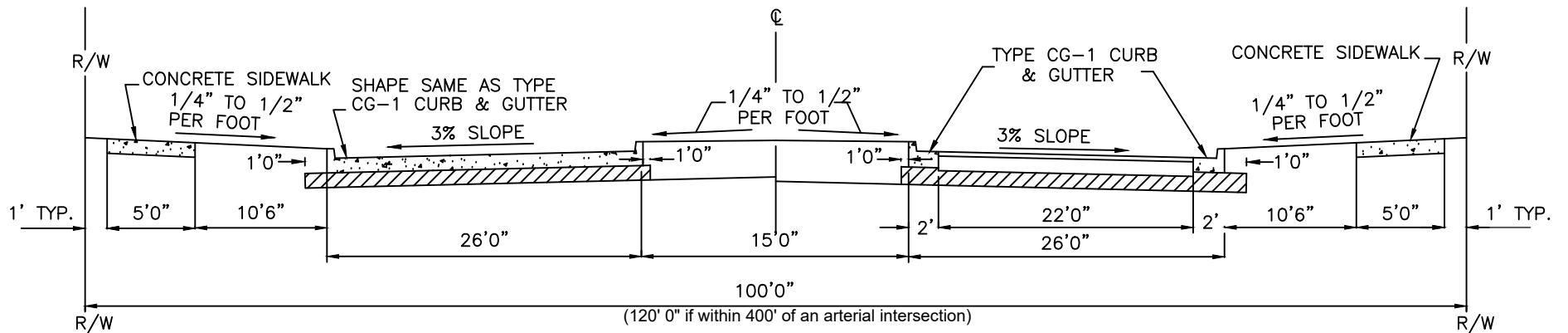

DUAL LANE 4-LANE

<p><u>TYPE A CONSTRUCTION</u> (Minimum Thickness)</p> <div style="display: flex; align-items: center; margin-bottom: 5px;"> <div style="width: 20px; height: 10px; background: repeating-linear-gradient(45deg, transparent, transparent 2px, black 2px, black 4px); border: 1px solid black; margin-right: 5px;"></div> <p>9" Portland Cement Concrete Pavement</p> </div> <div style="display: flex; align-items: center; margin-bottom: 5px;"> <div style="width: 20px; height: 10px; background: repeating-linear-gradient(-45deg, transparent, transparent 2px, black 2px, black 4px); border: 1px solid black; margin-right: 5px;"></div> <p>6" Compacted Subgrade Street Specification Section 1.02</p> </div>	<p><u>TYPE B CONSTRUCTION</u> (Minimum Thickness)</p> <div style="display: flex; align-items: center; margin-bottom: 5px;"> <div style="width: 20px; height: 10px; background-color: #cccccc; border: 1px solid black; margin-right: 5px;"></div> <p>2" Type 3 Asphaltic Concrete Surface</p> </div> <div style="display: flex; align-items: center; margin-bottom: 5px;"> <div style="width: 20px; height: 10px; background-color: #cccccc; border: 1px solid black; margin-right: 5px;"></div> <p>10" Type 1 Asphaltic Concrete Base</p> </div> <div style="display: flex; align-items: center; margin-bottom: 5px;"> <div style="width: 20px; height: 10px; background: repeating-linear-gradient(-45deg, transparent, transparent 2px, black 2px, black 4px); border: 1px solid black; margin-right: 5px;"></div> <p>6" Compacted Subgrade Street Specification Section 1.02</p> </div>
---	---



Notes:

1. All curb, sidewalk and Portland Cement pavement shall be KCMMB 4K concrete.
2. Type 2 Asphaltic Concrete is not allowed in any lift of Type B construction.
3. Engineer shall submit pavement designs if deviating from standard profiles shown above.

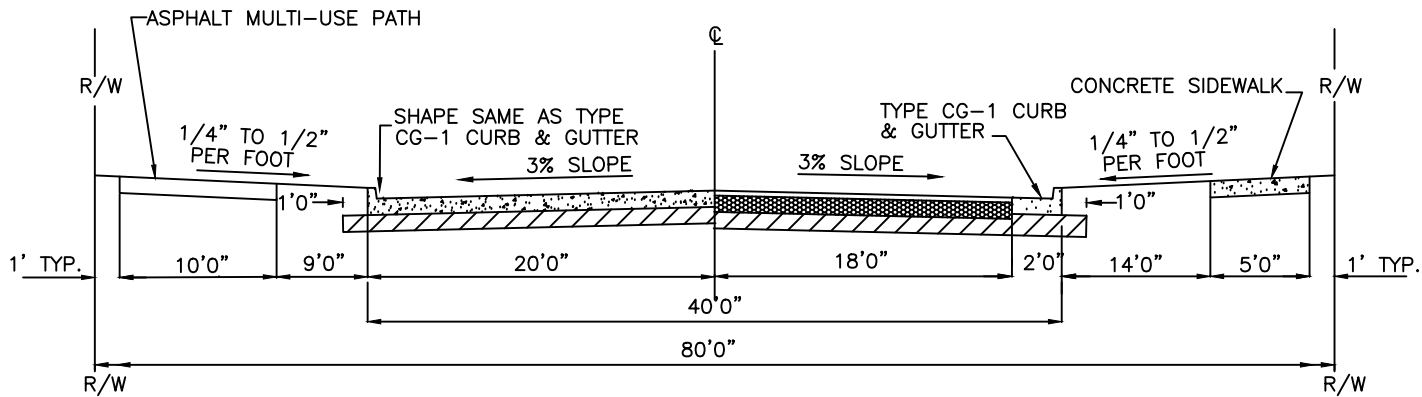
<p><i>PLANNING & ENGINEERING</i> 100 MUNICIPAL CIRCLE RAYMORE, MO 64083 (816)331-0488</p>		<h1 style="margin: 0;"><i>CITY OF RAYMORE</i></h1>			
<p>MINOR ARTERIAL STREETS</p>		<p>MINOR ARTERIAL STREETS</p>			
DRAWN Modified 1/11/18	DATE	SIZE A	FSCM NO.	DWG NO. ST-1a	REV
APPROVED		SCALE NONE		SHEET	OF

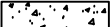
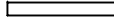
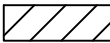

STANDARD-2 LANES

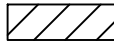
<u>TYPE A CONSTRUCTION</u> (Minimum Thickness)		<u>TYPE B CONSTRUCTION</u> (Minimum Thickness)	
	7" PORTLAND CEMENT CONCRETE PAVEMENT		2" TYPE 3 ASPHALTIC CONCRETE
	6" COMPACTED SUBGRADE STREET SPECIFICATION SECTION 1.02		7" TYPE 1 ASPHALTIC CONCRETE BASE COURSE
			6" COMPACTED SUBGRADE STREET SPECIFICATION SECTION 1.02

NOTE:

1. All curb, sidewalk and Portland Cement pavement shall be KCMMB 4K Concrete.
2. Type 2 Asphaltic Concrete is not allowed in any lift of Type B Construction
3. Engineer shall submit pavement design if deviating from standard profiles shown above.
4. Asphalt Multi-Use Path:
 - Subgrade stabilized per Street Specifications section 1.02
 - 4" Type 1 Base Asphalt
 - 2" Type 3 or Type 5 Surface Asphalt

PLANNING & ENGINEERING 100 MUNICIPAL CIRCLE RAYMORE, MO 64083 (816)331-0488		CITY OF RAYMORE			
		MAJOR COLLECTOR STREETS			
DRAWN 1/12/18	DATE	SIZE A	FSCM NO.	DWG NO. ST-2	REV
CHECKED		SCALE NONE		SHEET 1 OF 1	
APPROVED					

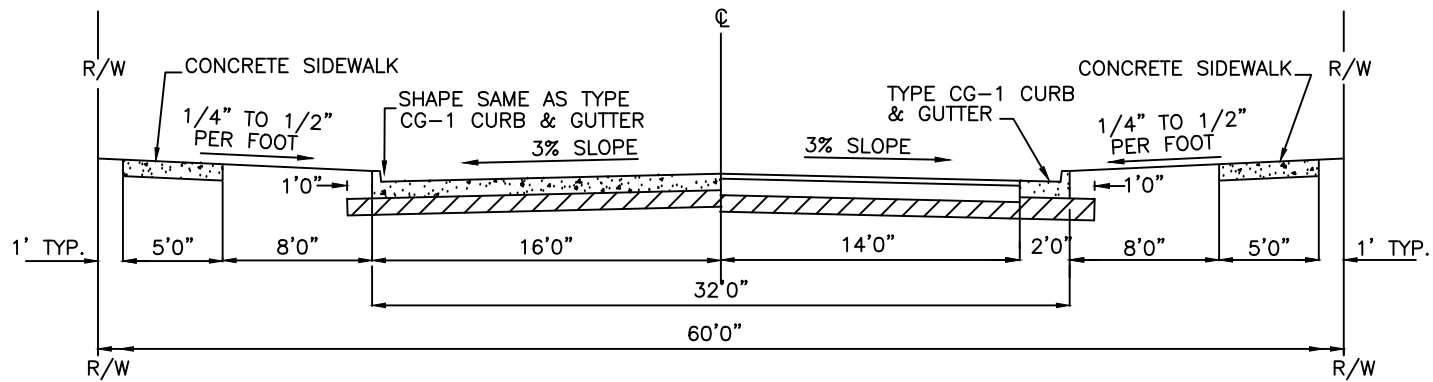

STANDARD 2-LANES

TYPE A CONSTRUCTION (Minimum Thickness)

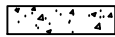

7" PORTLAND CEMENT CONCRETE PAVEMENT



6" COMPACTED SUBGRADE
STREET SPECIFICATION SECTION 1.02

TYPE B CONSTRUCTION (Minimum Thickness)

2" TYPE 3 ASPHALTIC CONCRETE

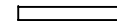

7" TYPE 1 ASPHALTIC CONCRETE
BASE COURSE



6" COMPACTED SUBGRADE
STREET SPECIFICATION SECTION 1.02



NOTE:

1. All curb, sidewalk and Portland Cement pavement shall be KCMMB 4K Concrete.
2. Type 2 Asphaltic Concrete is not allowed in any lift of Type B Construction
3. Engineer shall submit pavement design if deviating from standard profiles shown above.
4. Asphalt Multi-Use Path:
 - Subgrade stabilized per Street Specifications section 1.02
 - 4" Type 1 Base Asphalt
 - 2" Type 3 or Type 5 Surface Asphalt

PLANNING & ENGINEERING
100 MUNICIPAL CIRCLE
RAYMORE, MO 64083
(816)331-0488

CITY OF RAYMORE

MINOR COLLECTOR STREETS

DRAWN 1/12/18 DATE

CHECKED

APPROVED

SIZE A FSCM NO. DWG NO. ST-2A REV

SCALE NONE SHEET 1 OF 1

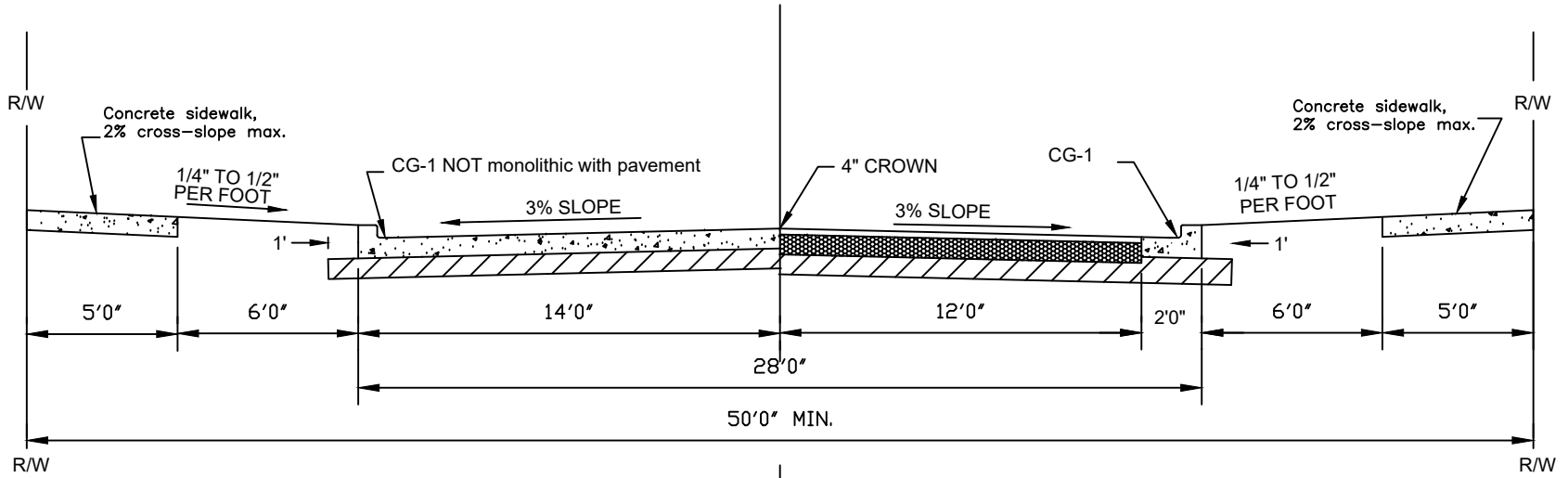

TYPE D CONSTRUCTION (Minimum Thickness)

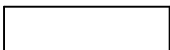
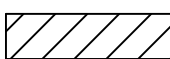
-  6" Portland Cement Concrete
-  6" Compacted Subgrade
Street Specification Section 1.02

TYPE E CONSTRUCTION (Minimum Thickness)

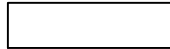
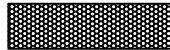
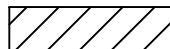
-  2" Type 3 Asphaltic Concrete Surface
-  6" Type 1 Asphaltic Concrete Base
-  6" Compacted Subgrade
Street Specification Section 1.02

NOTE:

1. All curb, sidewalk and Portland cement pavement shall be KCM MB 4K concrete.
2. Type 2 Asphaltic Concrete is not allowed in any lift of Type E construction.
3. Engineer shall submit pavement designs if deviating from standard profiles shown.

Engineering Department City of Raymore 100 Municipal Circle Raymore, MO 64083 816-331-0488	
DRAWN Modified 10/15/20	DATE
CHECKED	
APPROVED	

<i>CITY OF RAYMORE</i>			
LOCAL STREET			
SIZE A	FSCM NO.	DWG NO. St -3	REV
SCALE NONE	SHEET 1 OF 1		

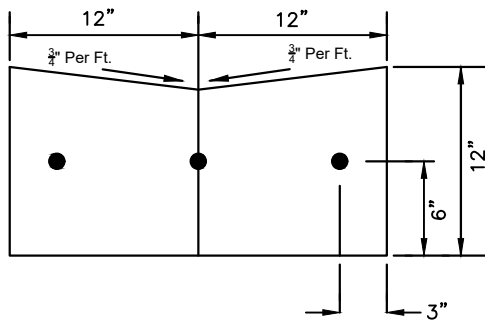
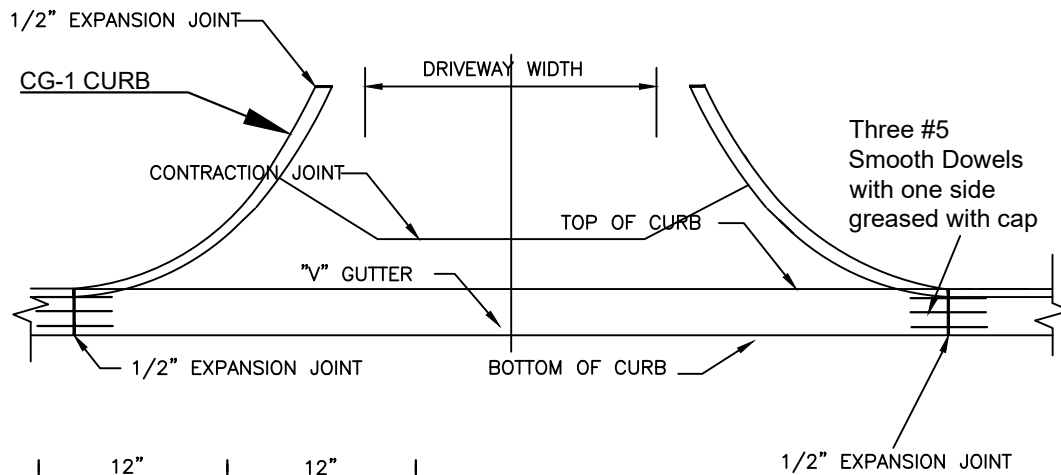
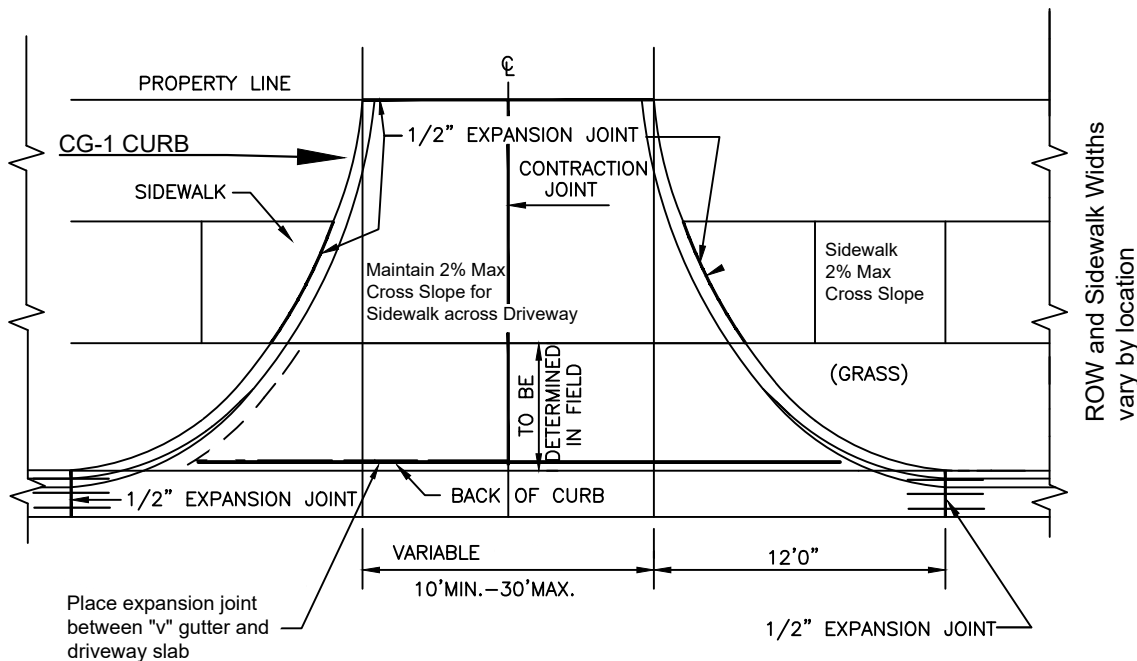

"V" Gutter Section

Notes:

1. All concrete shall be a KCMMB 4k mix design.
2. Place expansion joint between CG-1 curb and driveway slab (not shown for clarity) in addition to locations shown in detail. No monolithic pours.
3. Slab shall be 8" thick with no reinforcing steel required.
4. Contraction joints shall be located so as to form no panel larger than 12' by 12'. Joints are to be sawed 2" deep.
5. Drive shall slope towards the curb at 1/4" to 1/2" per foot, except thru the sidewalk area where the slope shall not exceed 1/4" per foot.
6. A leveling course of AB3 shall be placed as base material for all driveway approaches as required. Any over-excavated subgrade shall be completely filled with concrete, backfilled with AB3 or backfilled with suitable material and compacted.

ENGINEERING DEPARTMENT 100 MUNICIPAL CIRCLE RAYMORE, MO 64083 (816)331-0488		CITY OF RAYMORE			
DRAWN Modified 3/3/2020		DATE		DRIVEWAYS (CONCRETE) COMMERCIAL	
CHECKED		SIZE FSCM NO.		DWG NO. ST-9	
DESIGN		SCALE NONE		REV	
				SHEET 1 OF 1	

Typical Plan of Residential Driveway and Curb Replacement

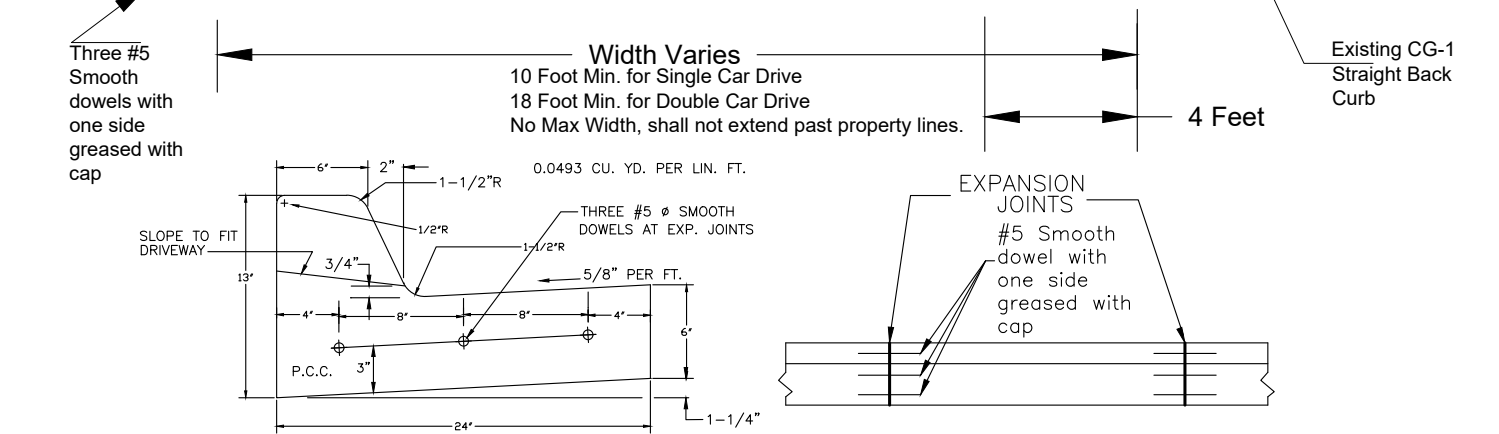
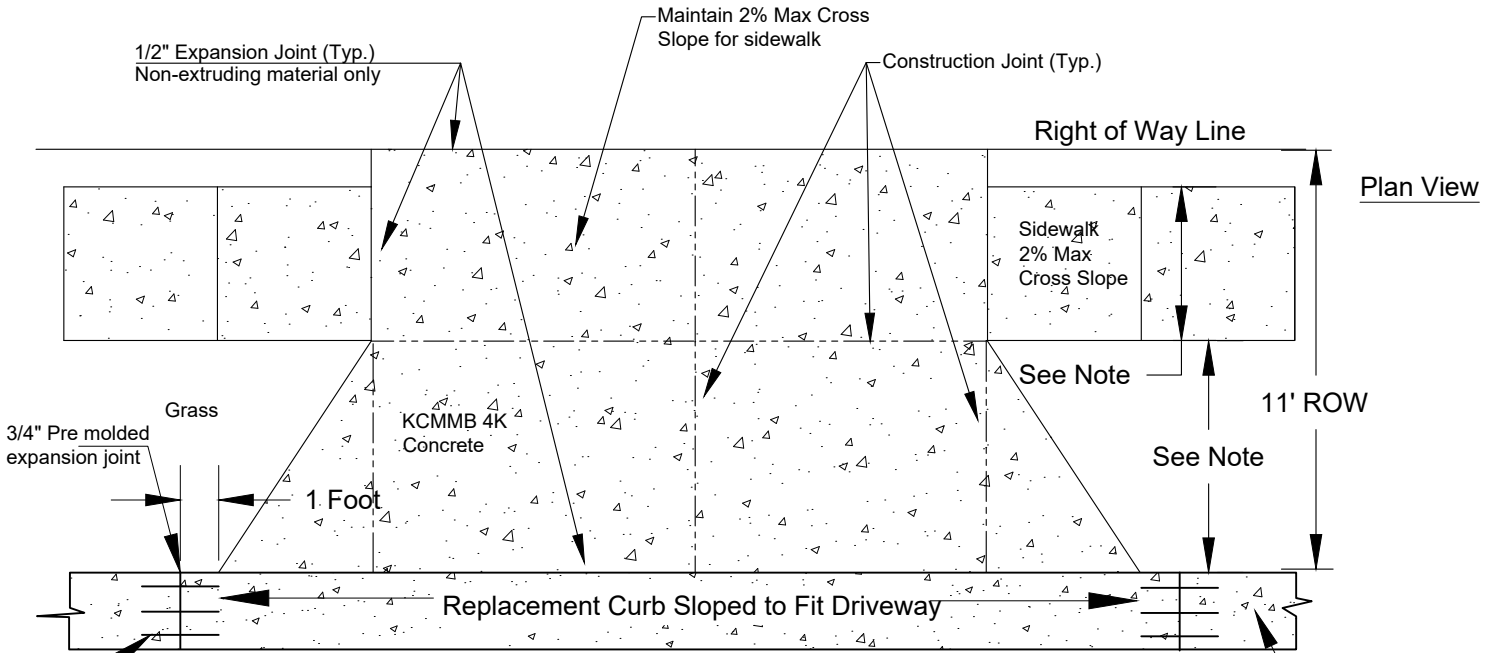

CROSS SECTION AT EXPANSION JOINT

STRAIGHT BACK CURB REPLACEMENT

Notes:

1. All concrete is to be KCMMB 4K. This includes flatwork behind the ROW line.
2. All residential driveway approaches shall be constructed using six-inch thick concrete with no reinforcing steel required.
3. Driveway and curb replacement in ROW requires a ROW permit.
4. A leveling course of AB3 shall be placed as base material for all driveway approaches as required. Any over-excavated subgrade shall be completely filled with concrete, backfilled with AB3 or backfilled with suitable material and compacted.
5. Non-extruding expansion material only.
6. 2" deep curb construction joints shall be spaced every 10 feet.
7. All exposed concrete shall be sprayed with cure as soon as finishing permits.
8. Sidewalk and green space widths vary by location.
9. Example shown using CG-1, use CG-2 or modified curb where appropriate.

Engineering Department
City of Raymore
100 Municipal Circle
Raymore, MO 64083
816-331-0488

CITY OF RAYMORE

DRIVEWAYS-CURB REPLACEMENT

DRAWN Modified 2018	DATE
CHECKED	
APPROVED	

SIZE A	FSCM NO.	DWG NO. St - 10	REV
-----------	----------	--------------------	-----

SCALE NONE SHEET 1 OF 1

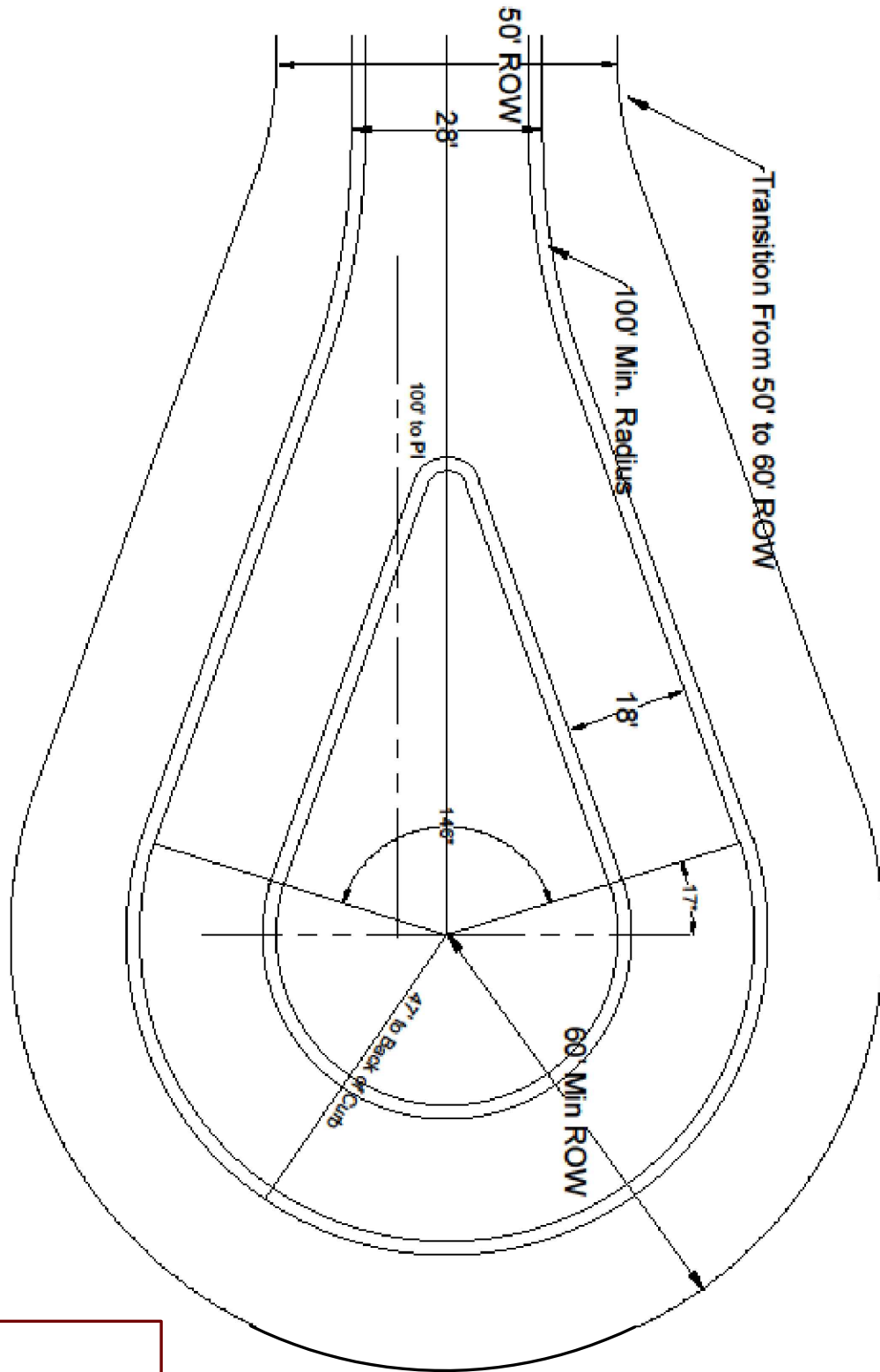

Engineering Department
 City of Raymore
 100 Municipal Circle
 Raymore, MO 64083
 816-331-0488

CITY OF RAYMORE

TEAR DROP CUL-DE-SAC

DRAWN 1/24/2018	DATE
CHECKED	
APPROVED	

SIZE A	FSCM NO.	DWG NO. St - 16	REV
SCALE NONE		SHEET 1 OF 1	