



**STANDARD CONTRACT DOCUMENTS
AND
TECHNICAL SPECIFICATIONS
FOR
UTILITY AND STREET CONSTRUCTION**

September 2019

**CITY OF RAYMORE, MISSOURI
100 Municipal Circle Raymore, Missouri 64083
816-331-1852 (Telephone) 816-331-8067 (Fax)**

STANDARD CONTRACT DOCUMENTS AND TECHNICAL SPECIFICATIONS
FOR UTILITY AND STREET CONSTRUCTION

CITY OF RAYMORE, MISSOURI

TABLE OF CONTENTS (2019)

<u>SECTION</u>	<u>Standard Technical Specifications</u>
Table of Contents	Contract Documents
Advertisement for Bids	Contract Documents
Information for Bidders	Contract Documents
Bid Proposal Form	Contract Documents
Agreement	Contract Documents
Performance Bond	Contract Documents
Maintenance Bond	Contract Documents
Payment Bond	Contract Documents
Notice of Award	Contract Documents
Notice to Proceed	Contract Documents
General Conditions	Contract Documents
Sanitary Sewer Specifications	Sanitary Sewer
Standard Sanitary Details	Sanitary Sewer
Storm Sewer Specifications	Storm Sewer
Standard Storm Details	Storm Sewer
Water Specifications	Water
Standard Water Details	Water
Street Specifications	Street
Standard Street Details	Street

Sanitary Sewer Specifications

1.00 GENERAL DESIGN STANDARDS

1.01 General

The design standards present in this Article are the minimum standards to be followed in the design of the City of Raymore Public sewerage system. These standards are not intended to be used as a substitute for actual construction specifications and design computations.

1.02 Design Factors

1. Sewerage systems which provide for a complete watershed shall be designed and sized taking either of the following into consideration:
 - a. The estimated tributary population for a period of 50 years hence
 - b. The entire watershed shall be assumed to be completely built-up according to present or predicted land use intensities, whichever required the greater capacity.
2. Sewerage systems which provide for only a part of a complete watershed shall be sized to provide for the entire watershed. Otherwise, provision shall be made for future increased capacity. Proper modification to allow for the characteristics (i.e., domestic, commercial and industrial wastes and groundwater infiltration) of the area under consideration shall be made.
3. Trunk and subtrunk sewerage shall be designed on a basis of population density of not less than ten persons per acre. Design provisions in excess of this minimum shall be made where the City Engineer deems it necessary.

1.03 Capacities

1. In determining the required capacities of sanitary sewers, the following factors shall be considered:
 - a. Maximum hourly quantity of domestic sewage;
 - b. Additional maximum sewage or waste from industrial plants and commercial areas;
 - c. Groundwater infiltration;
 - d. New sewerage systems shall be designed on the basis of an average per capita flow of sewage from the equivalent population served of not less than 100 gallons per day.

2. The 100 gallons per capita per day figure is assumed to cover normal infiltration, but an additional allowance shall be made where conditions are especially unfavorable. This figure is likewise considered sufficient to cover the flow from basement floor drains, but is not sufficient to provide an allowance for flow from foundation drains, roof leaders or unpolluted cooling water, which are hereby prohibited from discharging into sanitary sewerage systems.
3. Unless evidence is presented to prove a different flow from industry at ultimate development, the minimum allowance for industrial flow shall be determined by providing an equivalent population of 40 persons per acre or one equivalent population per employee, whichever is the greater, in the industrial area. Area shall include the entire area zoned for industry, except public road, street and highway rights-of-way; floodplains in which construction is prohibited; and green zones separating industrial from residential areas on which construction is prohibited.
4. The minimum allowance for flow from commercial areas shall be determined by providing an equivalent population of 30 persons per acre, or one-half equivalent population per employee, whichever is the greater, in the commercial area. Area shall include the entire area zoned for commercial development, including off-street parking areas and landscaped areas, but excluding the rights-of-way of public records, streets and highways; floodplains of streams on which construction is prohibited; and green zones 100 feet or more wide separating commercial from residential areas on which construction is prohibited.
5. In cases where the above criteria are not applicable, an alternate design procedure may be submitted to the City Engineer for approval. A description of the procedure used and justification for the modifications for sewer design proposed shall be included with the design analysis and plans submitted for approval.

1.03 Minimum Size of Sewer Pipe

No public sewer shall be less than eight inches in diameter. Service lines for Industrial and Commercial development shall not be less than six inches in diameter and Residential development shall not be less than four inches in diameter.

1.04 Hydraulic Design

1. Sewers shall have a uniform slope and horizontal alignment between manholes.
2. When a smaller sewer joins a large one, the invert of the larger sewer should be lowered sufficiently to maintain the same energy gradient. An approximate method for securing these results in place the 0.8 depth point of both sewers at the same elevation.

3. Sewers shall be designed to be free flowing with the hydraulic grade below the top of pipe and with hydraulic slopes sufficient to provide an average velocity when running full of not less than 2.25 feet per second. Computations of velocity of flow shall be based on the following Manning formula.

V	Velocity (FPS)
Q	Pipe flow capacity (CFS)
A	Inside area of pipe (FT ²)
R	Hydraulic Radius (FT)
S	Pipe slope (FT/FT)
n	Pipe roughness coefficient
Values for n shall be as follows:	
RCP - 0.013	
PVC - 0.010	
DIP - 0.014	

4. The maximum permissible velocity at average flow shall be 15 feet per second (FPS). Drop manholes shall be provided as shown on Standard Details San - 5 to break the steep slopes to limit the velocities to 15 FPS in the connecting sewer pipes between manholes. Where drop manholes are impracticable for reduction of velocity, the sewer shall be of ductile iron or concrete.
5. The following are minimum slopes in feet per hundred feet to be provided for pipes flowing from one-fourth of full depth to full depth:

Sewer Size (Inches)	Slope (feet Per 100 FT)
8	0.60
10	0.42
12	0.33
15	0.24
18	0.19
21	0.16
24	0.13
30	0.13
36	0.13
42	0.13

The terminal sections of sewers discharging into lift stations, sewer treatment plants, plant effluent into streams, etc., will require a minimum slope twice that indicated in the above table. The terminal section of sewer is defined as the section of sewer from the last manhole and will be a minimum of 100 feet.

1.05 Manholes

Manholes for access to sewers shall be provided to all intersections with other sewers, at all points of change in horizontal alignment, at all changes in vertical grade and at the terminal of the line. In addition, access manholes shall be provided at intervals not exceeding 400 feet on all sewers. Manholes shall be located in the street right-of-way not under the paved area unless approved by the City Engineer.

Manholes shall be designed and constructed to conform to ASTM C478 as shown on Standard Details San-1, San-2 and San-3.

Manholes for sewers up to 24 inches in diameter shall not be less than four feet inside diameter. Manholes for sewers larger than 24 inches shall have an inside diameter of not less than five feet.

A wall thickness not less than one-twelfth ($1/12$) of the inside diameter or four (4) inches, whichever is greater, shall be used when the manhole depth is less than sixteen (16) feet; one-twelfth ($1/12$) of the inside diameter plus one (1) inch or five (5) inches, whichever is greater, shall be used when the manhole depth is sixteen (16) feet or greater.

At manholes where the invert of the inlet sewer is more than 24 inches higher than the invert of the outlet sewer, a drop connection shall be provided as shown on Standard Detail San-3.

Unless improvements such as street grades will not permit, top of manholes shall extend a minimum 1'0" above the calculated 100 year floodwater elevation, provided that such extension shall not exceed four feet above final finish grade. Where this requirement results in an exposed manhole above final finish grade, a flat top manhole shall be used, be waterproofed and equipped with watertight ring and bolted down cover assembly with neoprene gaskets.

2.00 MATERIALS

2.01 Sewer Pipes

1. Reinforced Concrete Pipe – Reinforced concrete pipe and fittings shall conform to the requirements of ASTM C76. Gaskets shall be neoprene or other synthetic rubber. Natural rubber will not be accepted.
2. Ductile Iron Pipe – Ductile iron pipe shall conform to AWWA C151, Class 50 minimum. Joints shall be mechanical or push-on joints and conform to the current specifications ANSI 21.11. Gaskets shall be neoprene or synthetic rubber material. Natural rubber gaskets will not be acceptable. Ductile iron pipe must be labeled "Sewer". Fittings shall conform to the current AWWA Specifications C110 and C153 and shall have a pressure rating of not less than that specified for the pipe.

3. Polyvinyl Chloride Pipe (PVC) – Polyvinyl chloride pipe shall conform to ASTM D3034, Type PSM. The minimum wall thickness shall conform to SDR 35. Service lines shall be SDR 26 (minimum).

Flexible gasketed joints shall be compression-type with an integral bell. The integral bell shall have an elastomeric gasket ring conforming to the requirements of ASTM F477. Gaskets shall be neoprene or other material. Natural rubber gaskets will not be acceptable.

Fittings, tee's and bends, cleanouts, reducers, or other configurations required, shall be the same material as the pipe.

For sewer pipe with depth of cover exceeding 15 feet, the Engineer shall make earth loading analysis to determine if increased pipe strength is required in accordance with manufacturer specifications.

2.02 MANHOLES

Manholes shall be constructed complete with ring and cover, and other appurtenances, in accordance with the following criteria and standard details.

1. Concrete – 4000 PSI mix with entrained air.
2. Precast Sections – Circular precast concrete shall meet the requirements of ASTM C478. Joints shall be a bitumastic material or preformed flexible joint sealant. The exterior of all joints shall be sealed with Hamilton-Kent "Kent Seal" tape or *approved equal*.
3. Dimensions – Standard Details San-1, San-2, and San-3.
4. Flexible Joint – Hamilton-Kent "Kent Seal", Bidco Sealant, Inc. "Bidco C56" or *approved equal*. The minimum bead dimensions shall be one square inch.
5. Coal Tar Paint – Koppers "Bitumastic Super Service Black", Tnemec "46 450 Heavy Tnemecol", Porter "Tar Mastic 100" or *approved equal*.
6. Flexible Gaskets – Flexible gaskets shall be Press-wedge, PSX (Press Seal Gasket Corporation), A-Lok (A-Lok Products, Inc.) or *approved equal*.
7. Portland Cement – Portland Cement shall conform to ASTM C150, Type I or II. When high early strength is required, Type III can be used.
8. Fine Aggregate – Fine aggregate shall meet the requirements of ASTM C33.
9. Coarse Aggregate – Coarse aggregate shall meet the requirements of ASTM C33.

10. Mortar – One part Portland Cement, Type II, three parts sand, one-fourth part Hydrated lime, conforming to ASTM C207.
11. Manhole Steps – Steps are NOT permitted in manholes.
12. Reinforcing Steel – ASTM A615, Grade 40 or Grade 60.
13. External joints- All external joints shall be sealed using Cretex or an *approved equal*. Joint Seal shall be applied per manufacturer recommendations.
14. Chimney Seal- All Manhole Frame and Lids shall be sealed to the manhole with a Cretex external chimney seal or *approve equal*. Chimney Seal shall be applied per manufacturer recommendations.

2.03 CASTINGS

1. Manhole Ring and Covers (Standard Detail San-4) shall be as follows:
 - a. Clay & Bailey → Model No. 2008
 - b. Neenah → Model No. R-1669-A1
 - c. Deeter → Model No. 1315-M
 - d. EJIW → Model No. NPR11-1281A
2. Manhole Frame with Bolted Lid (Standard Detail San-5) shall be as follows:
 - a. Clay & Bailey → Model No. 2014OR
 - b. Neenah → Model No. R-1916E

3.00 INSTALLATION

3.01 Handling and Storage.

All pipe, fittings and accessories shall be loaded, unloaded, stored and installed in such a manner to prevent structural damage or coating damage. Any damaged material shall be replaced or restored to its original condition at the Contractor/Developer's expense.

3.02 Inspection of Materials

A Public Works Inspector will inspect pipe, fittings and accessories for damage or defect prior to installation. Damaged or defective materials shall be replaced or restored to its original condition.

3.03 Alignment

Pipe shall be laid to the lines and grades as shown on the approved Engineering drawings.

3.04 Cleaning

All pipes, fittings and accessories shall be kept clean of foreign matter while being handled or stored. During installation, foreign matter shall not enter the pipe or appurtenances. At the end of each working day, a temporary plug shall be installed at the termination of the pipeline.

3.05 Aerial Crossing

Support shall be provided at all joints in pipe utilized for aerial crossings. The supports shall be designed to prevent frost heave, overturning or settlement.

Precautions against freezing, such as insulation and increased slope, shall be provided. Expansion jointing shall be provided between above-ground and below-ground pipe.

The impact of flood waters and debris shall be considered in the design of aerial stream crossing. The bottom of the pipe shall be placed no lower than the elevation of the calculated 50 year floodwater elevation except as may be approved by the City Engineer. Joints shall be located such that a full length section of pipe is centered over the center of the streams.

Sewers crossing streams shall be ductile iron pipe encased in concrete, Standard Detail San-6, with the encasement extending into the bank a minimum of 20 feet at each end of the aerial crossing.

3.06 Sewers in Relation to Water Main – Separation of Water Mains, Sanitary Sewers and Storm Sewers.

1. Adequate Separation Factors – The following factors should be considered in providing adequate separation:
 - a. materials and type of joints for water and sewer pipes
 - b. soil conditions
 - c. service and branch connections into the water main and sewer line
 - d. compensating variations in the horizontal and vertical connections
 - e. space for repair and alterations of water and sewer pipes
 - f. off-setting of pipes around manholes and other sewer structures.

2 Parallel Installation

Water mains shall be laid at least ten feet horizontally from any existing or proposed sanitary sewer and at least 10 feet horizontally from any storm sewer. The distance shall be measured edge to edge. In cases where it is not practical to maintain this separation, the department may allow deviation on a case-by-case basis, if supported by data from the design engineer. Such deviation may allow installation of the water main closer to a sewer, provided that the water main is laid in a separate trench or on an undisturbed earth shelf located on one side of the sewer and in either case, at such an elevation that the bottom of the water main is at least 18 inches above the top of the sewer. In cases where it is not practical to maintain either the proper horizontal or vertical separation, the department may allow deviation on a case-by-case basis, provided the sanitary sewer is designed and constructed equivalent to water pipe (i.e. DIP) and pressure tested to ensure water tightness prior to backfilling.

3. Crossings

Water mains crossing sewers shall be laid to provide a minimum vertical clear distance of 18 inches between the outside of the water main and the outside of the sewer. This shall be the case where the water main is either above or below the sewer. At crossings, a full length of water pipe shall be located such that both joints will be as far from the sewer as possible. Special structural support (i.e. encasement) for the water and sewer pipes may be required.

4. Exception

The department must specifically approve any variance from the requirements of Items 2 and 3 when it is impossible to obtain the specified separation distances.

5. Force Mains

There shall be at least a ten foot horizontal separation between water mains and sanitary sewer force mains. There shall be an 18 inch vertical separation at crossings as required in Item 3. There shall be a minimum of four foot of cover between the force main and the surface of both green and paved areas.

6. Sewer Manholes and Other Structures

No water line shall be located closer than ten feet to any part of a sewer manhole or other sanitary sewer structure. No water line will be located closer than five feet to any part of a storm sewer curb inlet, junction box, or other storm sewer structures.

3.07 Straddle Blocks

Straddle blocks shall be provided every 50 feet for sewers which exceed 15 feet per 100 feet in slope. Dimensions for straddle blocks shall be as

shown on Standard Detail San-7. Straddle blocks at shorter intervals may be required under extreme conditions as determined by the City Engineer.

3.08 Service Lines and Connections

Tee's, wyes, Inserta Tee's, and saddles for service lines shall be installed at a 45 degree angle measured from the centerline of the pipe for the pipe sizes eight inches through 15 inches in diameter. Service lines shall not be installed in pipe sizes 18 inches or larger.

Service lines under streets shall be installed by the Contractor/Developer extending from the main to the limits of the street right-of-way and shall be installed prior to construction of the street at a slope not less than one foot per 100 feet. Service lines for each building unit shall be connected to the mains by means of a wye or tee and shall extend at least to the street right-of-way, but never less than (10) feet from the sewer main. Individual service lines shall not connect directly into manholes unless approved by the City Engineer. Service lines shall be adequately plugged to prevent foreign matter from entering the pipe during construction. All service lines shall be constructed bell to spigot or shall have a solid glued sleeve.

Inserta Tee's shall be used to connect to existing sanitary sewer. Saddles may also be used if approved by the City Engineer. Saddles may be installed over a hole cut with a four (4) inch circular bit equal in diameter to the service line. Square cut holes are not permitted.

The Contractor/Developer shall mark the service lines and/or tees with a metal t-post at the street right-of-way so they can be detected at a depth of 24 inches during excavation.

The Contractor/Developer shall maintain an accurate record for the production of the as-built mylars of the location, size and direction of each tee and wye, and location, size and length of each building service line. Locations will be referenced to the pipeline stationing as shown on the plans, or the distance from the first downstream manhole.

3.09 Dead End Sewer Lines

All dead end sewer lines, which are to be extended in the future, shall be installed to the limits of the platted subdivision such that extensions to the lines to serve adjacent subdivision plats may be connected at the plat boundary. A stub line shall be placed into the manhole for extension in the future to serve adjacent property; the line shall be a minimum of ten feet in length and shall include a watertight plug at the end furthest from the manhole.

3.10 Private Sewer Systems

Sewer systems not meeting the requirements of The City of Raymore Sanitary Sewer Specifications will not be considered for public dedication.

3.11 Manholes

When placing a manhole over an existing sewer line, the area shall be kept dry and clean while placing the concrete for the invert and doghouse. The concrete surface of the doghouse area shall be scarified. Six inch "Kent Seal" tape shall be placed around the pipe and the doghouse area. Non-shrink grout shall be used and shall be placed from 12 inches outside of the manhole to 4 inches inside the manhole and a minimum depth of 8 inches below the pipe.

When connecting a new sewer line to an existing manhole, a circular bit must be used to core the manhole and an A-Lok (A-Lok Products, Inc.) gasket, or approved equal, must be used.

4.00 ACCEPTANCE TESTS

4.01 General

The Public Works Inspector shall be permitted access to the construction work at any time for inspection of the work and construction methods. Work not conforming to the requirements of these standards shall be adequate basis for rejection of project until corrected to the satisfaction of the City Engineer.

4.02 Air Testing (Primary Testing Procedure) APWA 2509.2 b (2) For Gravity Sewers

1. One hundred (100) percent of the total linear footage of sewer installed on a given project shall be tested. .
2. The Contractor shall furnish all facilities required including necessary piping connections, test pumping equipment, pressure gauges, bulkheads, regulator to avoid over-pressurization, and all miscellaneous items required.
 - a. The pipe plug for introducing air to the sewer line shall be equipped with two taps. One tap will be used to introduce air into the line being tested, through suitable valves and fittings, so that the input air may be regulated. The second tap will be fitted with valves and fittings to accept a pressure test gauge indicating internal pressure in the sewer pipe. An additional valve and fitting will be incorporated on the tap used to check internal pressure so that a second test gauge may be attached to the internal pressure tap. The pressure test gauge will also be used to indicate loss of air pressure due to leaks in the sewer line.
 - b. The pressure test gauge shall meet the following minimum specifications:

Size (diameter)	4 - ½ inches
Pressure Range	0 - 15 P.S.I
Figure Intervals	1 P.S.I. increments
Minor Subdivisions	0.05 P.S.I.
Pressure Tube	Bourdon Tube of diaphragm
Accuracy	+ 0.25% of maximum scale reading
Dial and Mirror Edge	White coated aluminum with black lettering, 270 Arc
Pipe Connection	Low maile ½ " P.P.T.

Calibration data not over one year old will be supplied with all pressure test gauges. Certification of pressure test gauge will be required from the gauge manufacturer. This certification and calibration data will be available to the Public Works Inspector whenever air tests are performed.

3. Test each reach of sewer pipe between manholes after completion of the installation of pipe and appurtenances and the backfill of sewer trench.
4. Plug ends of line and cap or plug all connections to withstand internal pressure. One of the plugs provided must have two taps for connecting equipment. After connecting air control equipment to the air hose, monitor air pressure so that internal pressure does not exceed 5.0 psig. After reaching psig, throttle the air supply to maintain between 4.0 and 3.5 psig for at least two minutes in order to allow equilibrium between air temperature and pipe walls. During this time, check all plugs to detect any leakage. If plugs are found to leak, bleed off air, tighten plugs, and again begin supplying air. After temperature has stabilized, the pressure is allowed to decrease to 3.5 psig. At 3.5 psig, begin timing to determine the time required for pressure to drop to 2.5 psig. If the time, in seconds, for the air pressure to decrease from 3.5 psig to 2.5 psig is greater than that shown in the table below, the pipe shall be presumed free of defects.

Pipe Size	Required Time Per 100 LF	Maximum Required Time
8"	70 sec.	227 sec.
10"	110 sec.	283 sec.
12"	158 sec.	340 sec.
15"	248 sec.	425 sec.
18"	356 sec.	510 sec.
21"	485 sec.	595 sec.
24"	634 sec.	680 sec.
27"	765 sec.	765 sec.
30"	851 sec.	851 sec.
33"	935 sec.	935 sec.

If air test fails to meet above requirements, repeat test as necessary after all leaks and defects have been repaired.

4.03 Exfiltration and Infiltration Tests (Secondary Testing Procedure) APWA 2509.2.b (1) For Gravity Sewers for Pipe Diameters Greater Than 18" (ID)

At the option of the Contractor/Developer, sewers shall be tested for leakage by exfiltration (i.e., outward leakage trench dry) or infiltration (i.e., inward leakage, trench wet).

Leakage shall not exceed 200 gallons per inch of diameter of sewer per mile per day up to 24 inches in diameter. Leakage may be allowed up to 400 gallons per inch of diameter per mile per day for short sections of sewer lines between two adjacent manholes up to and including 12 inches in diameter. However, the average leakage on the system being tested for acceptance shall not exceed the two hundred (200) gallons per inch standard. For sewers larger than 24 inches in diameter, leakage shall not exceed 5,000 gallons per mile per day.

The leakage test shall be conducted on the first section of pipe laid by each crew before backfilling and before the crew is permitted to continue pipe installation. If, however, the contractor desires to backfill prior to testing, he may do so at his own risk, and shall be responsible for uncovering and repairing any section which does not meet the standards outlined above. The leakage test shall be conducted on all other sections of the system, as completed, in a matter acceptable to the department. All expenses connected with the test shall be borne by the contractor.

1. Leakage Test Procedures – The leakage tests shall be performed as follows:
 - a. Exfiltration test – Wherever possible, in the judgment of the Public Works Department, the sewer shall be subjected to the exfiltration test. The exceptions shall be where grades are excessive developing more than ten feet of pressure head within the pipe or where groundwater level would be higher than the internal pressure head developed by this test. All outlets and inlets shall be plugged and secured in a manner to resist the internal pressure of this test without leakage or failure. The test section shall be filled with water at the upstream manhole such that a minimum positive head of two (2) feet will be maintained during the test.

Manholes shall be included in such testing and shall be evaluated equivalent to the sewer pipe. This level of water shall be maintained as long as necessary to locate all leaks, but not less than two hours. Measurements shall be made of the rate of leakage (exfiltration) from the sewer by determining the amount of water required to maintain

the initial level at the top of the pipe. Water will be furnished to the Contractor/Developer, at cost, from an approved source provided with a meter.

- b. Infiltration test – Where the aforesaid exfiltration test cannot be run because of high groundwater level, the sewer shall be tested by measuring the actual infiltration during the wettest time of the year. A V-notch weir shall be installed at the lower end of the section to be tested and the maximum flow determined shall be the rate compared to the standards provided in this section and shall apply only to be submerged below the groundwater such that a continuous minimum head of two (2) feet is maintained. Manholes shall be included in such testing and shall be evaluated equivalent to the sewer pipe.

4.04 Visual Inspection-Mandrel Testing

Sewers will be inspected by physical passage of a mandrel or other approved deflection measuring device through the length of each pipe segment. The maximum allowable deflection shall not exceed five percent of the pipe's actual inside diameter as measured in the field. Mandrel testing shall be performed at least 30 days after backfill is placed. Contractor is responsible for performing the mandrel testing while a Public Works Inspector is present.

4.05 Vacuum Testing of Manholes

1. All Manholes shall be vacuum tested in the presence of a Public Works Inspector. The vacuum test shall consist of properly sealing the manhole openings, applying a vacuum equivalent to ten inches of mercury, and measuring the time the manhole will hold an acceptable level of vacuum. The Vacuum Test shall be performed in accordance with the following procedures:
 - a. Each manhole shall be tested after backfilling to, at least the level of the bottom adjustment ring. The vacuum test shall include testing of the seal between the cast iron frame and the concrete cone or slab.
 - b. All pipes entering the manhole shall be plugged at least eight inches into the sewer pipe. The plug shall be inflated at a location beyond the manhole/pipe gasket.
 - c. All plugs shall be adequately braced to prevent the plug or pipe from being dislodged and drawn into the manhole.
 - d. A vacuum of at least ten and one-half inches of mercury shall be drawn on the manhole. The valve shall be shut on the vacuum line to the manhole and the vacuum line shall be disconnected. The vacuum line valve shall be opened and the vacuum shall be adjusted to ten inches of mercury.

- e. The pressure gauge shall be liquid filled having a 3.5 inch diameter face with a reading from zero to thirty inches of mercury. The pressure gauge shall be calibrated a minimum of one time per year.
- f. The time for the vacuum reading to drop from ten inches of mercury to nine inches of mercury shall be equal to or less than the following times for the manhole to be considered as passing the vacuum test:

Manhole Depth	Time (minutes)
10 feet or less	2
10.1 to 15 feet	2.5
15.1 to 25 feet	3
25.1 or greater	3.5

- g. If a manhole fails the vacuum test, the manhole shall be uncovered and the leak repaired. The manhole shall then be backfilled and retested.

4.06 Acceptance Tests for Pressure Sewage Force mains AWWA C600 As Modified Per APWA 2509.3.

1. Perform hydrostatic pressure and leakage tests. Conform to AWWA C600 procedures as modified herein. Test shall apply to all pressure sewers. Perform after backfilling.
2. Test separately in segments between sectionalizing valves, between a sectionalizing valve and a test plug, or between test plugs. Select test segments such that adjustable seated valves are isolated for individual checking. Contractor/Developer shall furnish and install test plugs, including all anchors, braces, and other devices to withstand hydrostatic pressure on plugs. Contractor/Developer shall be responsible for any damage to public or private property caused by failure of plugs. Limit fill rate of line to available venting capacity.
3. Pressure test: Conduct at 1.5 times maximum operating pressure determined by the following formula:

$$P_{pt} = 0.650 (OP - GE), \text{ in which}$$

P_{pt} = test pressure in psi at gauge elevation

OP = operating pressure in feet as indicated for highest elevation of the hydraulic gradient on each section of the line.

GE = elevation in feet at center line of gauge

Perform satisfactorily prior to determining leakage.

4. Leakage Test: Conduct at maximum operating pressure determined by the following formula.

$P_{It} = 0.433 (OP - GE)$, in which
P_{It} = test pressure in psi at gauge elevation
OP and GE – as in Item 3 above

5.00 EXCAVATION, TRENCHING AND BACKFILLING

5.01 General

The trench shall be so dug that the pipe can be laid to the alignment and depth required and shall be excavated only so far in advance of pipe laying as the Engineer shall specify. The trench shall be so braced and drained that the workmen may work therein safely and efficiently. All trenches shall be sheeted and braced to a safe angle of repose. Such angle of repose shall be no less than that repose required by the requirements of the Occupational Safety and Health Act (OSHA).

It is essential that the discharge of any required trench dewatering pumps be conducted to natural public drainage channels, drains or storm sewers. Discharge location(s) shall be approved by the Engineer prior to dewatering.

5.02 Bedding

Granular bedding as shown on Standard Detail San-8 shall be used unless a different class of bedding is called for elsewhere in the contract documents. PVC pipe shall be bedded in accordance with the specifications described below. Any special bedding shall be in accordance with the Special Provisions.

1. Granular Bedding:

Granular bedding shall be achieved by bedding the pipe with ordinary care in an earth foundation formed in the trench bottom by a shaped excavation which will fit the pipe barrel with reasonable closeness for a width of at least 50% of the outside pipe diameter. The side fills and area over the pipe, to a minimum depth of six inches above the top of the pipe, shall be filled with embedment material. Embedment materials shall be granular bedding approved by the City. Embedment materials shall be compacted in six (6) inch lifts to a point six (6) inches above the pipe and to a density of at least ninety five (95) percent of standard proctor density as described by ASTM Methods D698.

2. Polyvinyl Chloride Pipe (PVC)

All PVC pipe shall be installed and bedded in accordance with ASTM Specification D-2321, "Recommended Practice for Underground Installation of Flexible Thermoplastic Sewer Pipe." Embedment materials shall be granular bedding approved by the City. Embedment materials

shall be compacted in six (6) inch lifts to a point six (6) inches above the pipe and to a density of at least ninety five (95) percent of standard proctor density as described by ASTM Methods D698. All embedment materials shall be tested for compliance with the above specification and test results shall be supplied to the Engineer. The Contractor, with an Engineer's representative present, shall check the deflection by means of pulling a mandrel or other 'go-no-go' device (approved by the Engineer) through the pipe prior to final acceptance and at least thirty (30) days after the sanitary sewer trench has been backfilled. Deflections greater than 5% of the inside diameter of the pipe shall be considered failure of the bedding/backfilling procedure. For deflections between 5% and 7.5%, the Contractor shall have the option of:

- a. Determining the extent of the deflections and accepting a reduced payment in accordance with the schedule shown below:

Deflection	Percent Reduction in Payment
5% or less	0%
5%-7.5%	25%
Greater than 7.5%	Pipe will be relaid

All deflections greater than 7.5% shall be corrected in accordance with Option 'b' stated below. The payment reduction, if exercised by the Contractor, will be applied to the entire length of the pipe between the manholes in which the deflection between 5% and 7.5% occurs.

- b. The Contractor shall be required to re-excavate the trench, recompact the backfill material and restore the surface at no additional compensation with the relaid pipe meeting the 5% requirement.

5.03 Trench Width and Description

The trench width at the top of the excavation may vary depending upon the depth of the trench and the nature of material encountered. The width of the trench shall also be kept at a minimum to prevent excess destruction of the existing ground surface.

For trench width at the top of the pipe greater than specified in the paragraph above, the Engineer may direct the Contractor to provide a higher class of bedding or a higher strength pipe (or both) than that required by the contract documents; without additional compensation therefore, as the Engineer deems necessary to satisfy the design requirements.

5.04 Correcting Faulty Grade

Any part of the trench excavated below grade shall be corrected with approved material and thoroughly compacted without additional compensation to the Contractor.

5.05 Pipe Foundation in Poor Soil

When the bottom of subgrade is soft and in the opinion of the Engineer cannot adequately support the pipe, a further depth and/or width shall be excavated and refilled to pipe foundation grade with material approved by the Engineer and thoroughly compacted; or other approved means such as piling, shall be adopted to assure a firm foundation for the pipe with extra compensation allowed the Contractor as provided elsewhere in these specifications.

This provision only applies in those instances/locations when normal dewatering operations are not considered viable and/or poor soil conditions exist as determined by the Engineer. The Contractor shall furnish, drive and place piling if ordered by the Engineer. Piles shall be driven in exact position at locations determined by the Engineer. The Contractor at his own expense must replace piles not correctly positioned at the completion of driving.

5.06 Pipe Foundation in Rock

The space between the bottom of the trench in rock conditions and the required bedding of the pipe as per Section 5.02 (Bedding) as shown on Standard Detail San-8, shall be backfilled with granular material, approved by the Engineer, thoroughly tamped. No additional compensation for placing or tamping this material shall be allowed.

5.07 Solid Rock Excavation Defined

Solid rock excavation shall include such rocks as are not decomposed, weathered or shattered and which will require extraordinary construction activities as determined by the Engineer including but not limited to blasting, barring, wedging or use of air tools for removal. Under this classification shall be included the removal of any concrete or masonry structure (except concrete pavement, curb, gutter and sidewalk) exceeding one (1) cubic yard in volume that may be encountered in the work.

5.08 Blasting Procedure

The hours of blasting will be fixed by the Engineer. The Contractor's methods of procedure relative to blasting shall conform to local and state laws and municipal ordinances.

5.09 Braced and Sheeted Trenches

The Contractor shall adequately brace and sheet excavation wherever necessary to prevent caving or damage to nearby property. The cost of this temporary sheeting and bracing, unless provided for otherwise, shall be considered as part of the excavation costs without additional compensation to the Contractor. Trench sheeting shall remain in place until pipe has been laid, compacted to a depth of one foot (1') over the top of the pipe. Sheeting, bracing, etc., placed in the "pipe zone" (that

part of the trench below a distance of one foot (1') above the top of the pipe) shall not be removed without the written permission or written order of the Engineer; that sheeting thereby left in place shall be paid for at the unit price bid. Sheeting ordered left in place by the Engineer in writing shall be paid for at the unit price bid. The Contractor may also leave in place, at his own expense, to be embedded in the backfill of the trench any sheeting or bracing in addition to that ordered left in place by the Engineer for the purpose of preventing injury or damage to persons, corporations or property, whether public or private, for which the Contractor under the terms of this contract is liable.

5.10 Piling of Excavated Material

All excavated material shall be piled in a manner that will not endanger the work and damage property that is to be avoided and that will avoid obstructing sidewalks and driveways. Gutters shall be kept clear or other satisfactory provisions made for street drainage.

5.11 Barricades, Guards, and Safety Provisions

At no cost to the Owner, the Contractor shall protect persons from injury and to avoid property damage, shall place and maintain adequate barricades, construction signs, torches, flashers and guards as required in accordance with the contract documents and the Manual on Uniform Traffic Control Devices during the progress of the construction work and until the site is returned to a safe and usable manner. All material piles, trenches, excavation equipment and pipe which may serve as hazards to the public shall be enclosed by fences or barricades and shall be protected by proper lights when the visibility is poor. The rules and regulations of the local and state authorities respecting safety provisions shall be observed.

5.12 Private Property Protection

The Contractor shall be responsible for, but not limited to, the protection of trees, fences, poles and all other private property unless their removal is authorized by the Engineer. Property damage shall be satisfactorily restored by the Contractor or adequate compensation therefore shall be the responsibility of the Contractor at no additional cost to the Owner.

5.13 Jack Steel Casing Pipe in Place

Steel casing pipe shall be jacked in place to provide a conduit for the carrier pipe.

The carrier pipe shall be installed within the casing pipe using "wooden skids" or similar devices to center the carrier pipe within the casing pipe. Upon completion of the carrier pipe installation, watertight removable end seals shall be installed for the casing conduit. Cathodic and corrosion protection are required depending on the carrier/casing pipe used.

Jacking shall be paid for at the contract unit price bid per lineal foot installed and shall include the casing pipe, jacking pits, cathodic and corrosion protection, watertight seal, dewatering and all other labor and materials necessary to complete the work.

The existing casings shall be cut or trimmed as shown on the plans. All labor and materials necessary to complete the work shall be considered incidental to the installation of the carrier pipe.

5.14 Backfill

Backfill under pavements, driveways, sidewalks, and other paved areas:

1. Flowable fill shall be used for backfill under all paved areas. Flowable fill mix design must be approved by the Engineer prior to placement. Backfill shall be placed as shown on Standard Detail St-11. (APWA p26-14)

Backfill in areas other than paved areas:

2. Backfill shall be finely divided, excavated material, free from debris, organic material, frozen material, and stones larger than six inches.

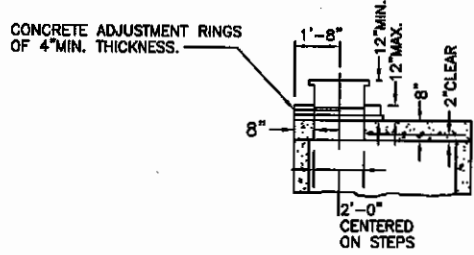
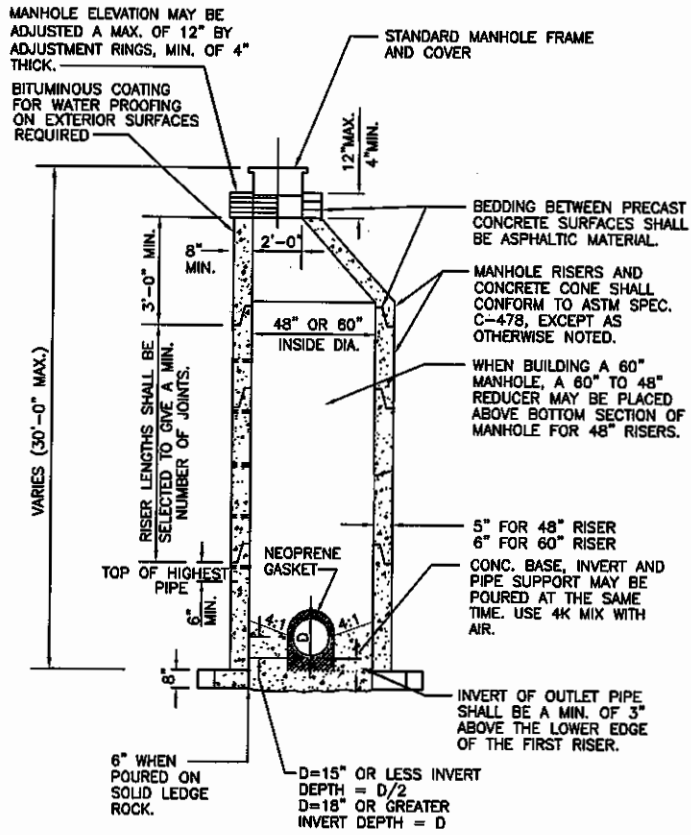
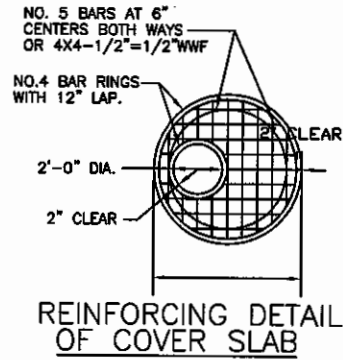
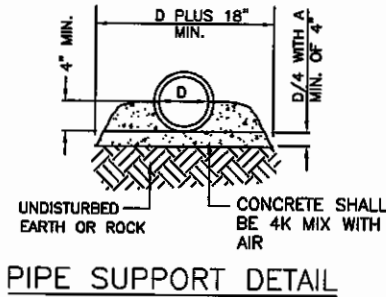
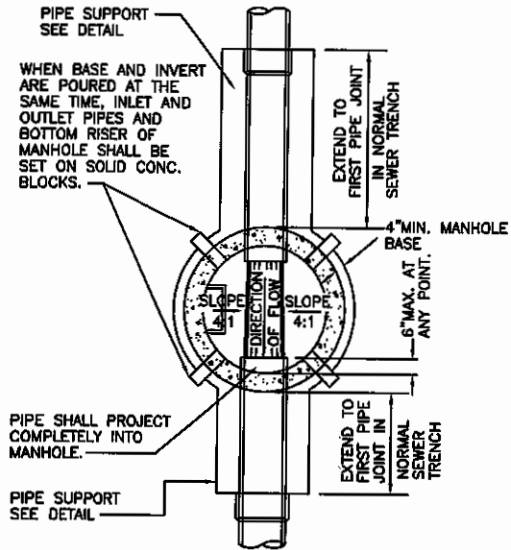

- GENERAL NOTES:**
1. Clearance tolerance of pipe openings.
The maximum allowable pipe opening on a horizontal axis shall be the outside diameter of the pipe plus 12".
The maximum allowable pipe opening on a vertical axis shall be the outside diameter plus 8".
The minimum clearance between the outside surface of an installed pipe and the concrete of the manhole shall be 2".
The maximum openings allowable for the drop manhole entry in the barrel shall be the outside diameter of the pipe plus 12".
 2. Installation of pipe openings.
All required pipe openings shall be plant cast in manhole units. Field alterations of openings will be permitted only with Engineer's approval.
 3. Minimum distance between any two adjacent pipes shall be 4".
 4. Joint Wrap or Chimney Seal Material around each joint.

Engineering Department
 City of Raymore
 100 Municipal Circle
 Raymore, MO 64083
 816-331-1852 Fax 816-331-8067

DRAWN
 modified 2013

CHECKED

APPROVED

CITY OF RAYMORE

MANHOLE - PRECAST CONCRETE
4'-0" OR 5'-0" DIA

SIZE	FSCM NO.	DWG NO.	REV
A		San - 1	
SCALE NONE		SHEET 1 OF 1	

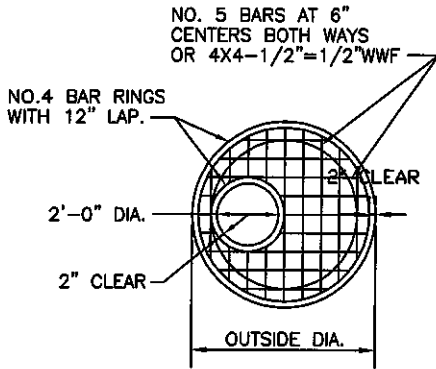

REINFORCING DETAIL OF COVER SLAB

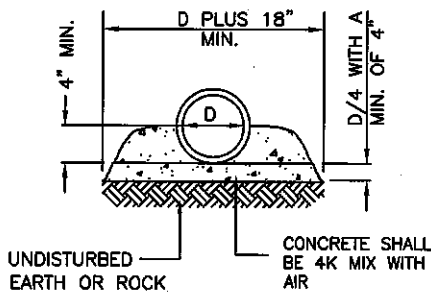

PIPE SUPPORT DETAIL

MANHOLE TOP ADJUSTMENT SHALL BE ACCOMPLISHED BY THE USE OF CONCRETE ADJUSTING RINGS (4" MIN. THICKNESS)

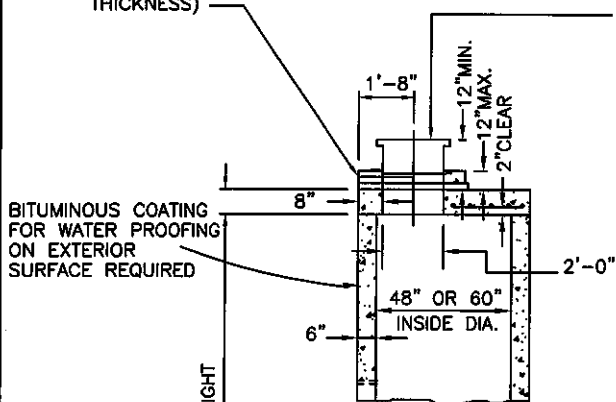

30'-0" MAXIMUM HEIGHT

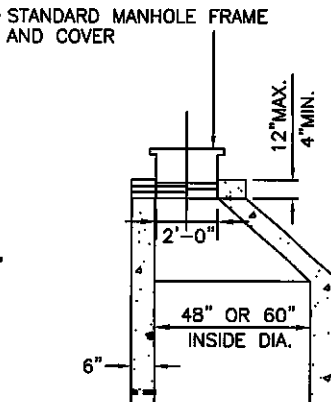

USING CONICAL SECTION

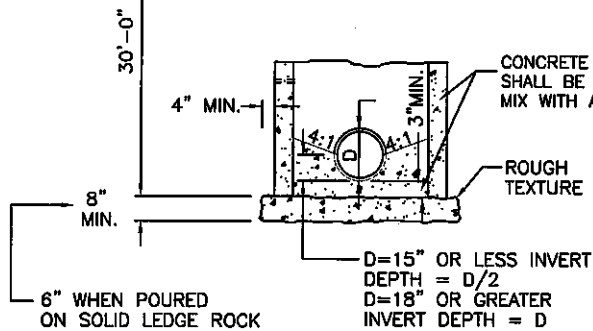
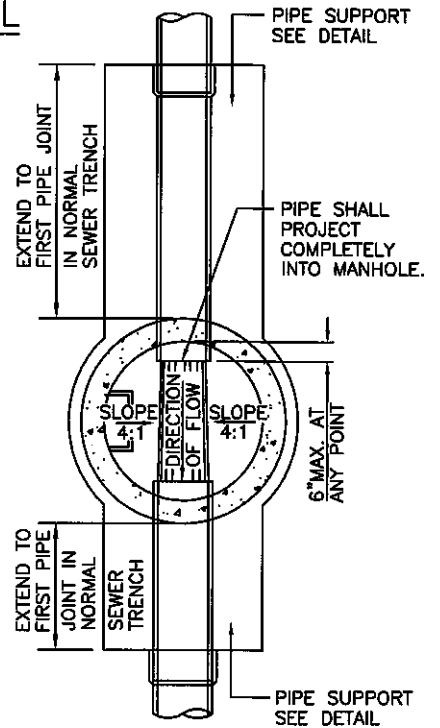

MONOLITHIC CONSTRUCTION

STAGE CONSTRUCTION

NOTES:

- ALL JOINTS AND ADJUSTMENT RINGS SHALL BE WRAPPED.
- MINIMUM DISTANCE BETWEEN ANY TWO ADJACENT PIPES SHALL BE 4".

Engineering Department
City of Raymore
100 Municipal Circle
Raymore, MO 64083
816-331-1852 Fax 816-331-8067

CITY OF RAYMORE

MANHOLE - CAST IN PLACE
4'-0" OR 5'-0" DIA.

DRAWN	Modified 2013
CHECKED	
APPROVED	

SIZE	FSCM NO.	DWG NO.	REV
A		San - 2	
SCALE	NONE	SHEET	1 OF 1

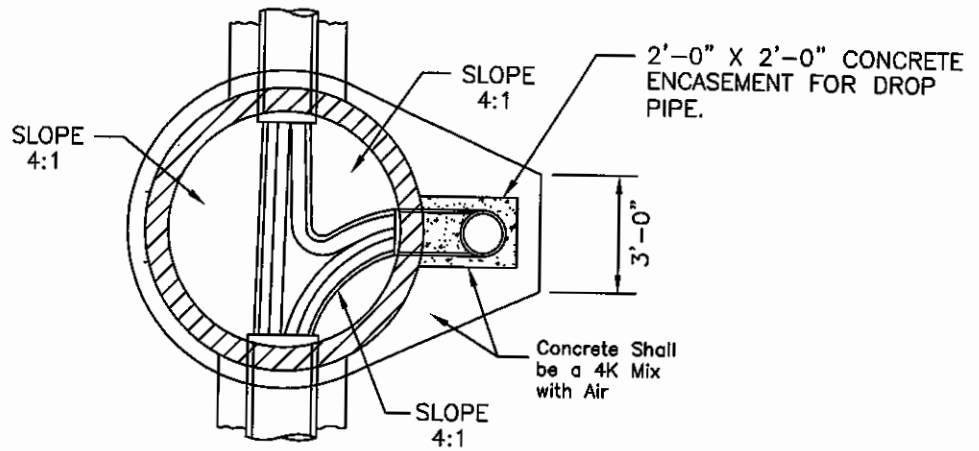

SECTION A-A

SIZE	C	A	B
8" ON 8"	3'-0"	2'-4"	1'-3"
10" ON 10"	3'-0"	2'-3"	1'-5"
12" ON 12"	3'-0"	2'-1"	1'-5"

CRADLE SHALL EXTEND TO THE CENTER OF THE INCOMING PIPE.

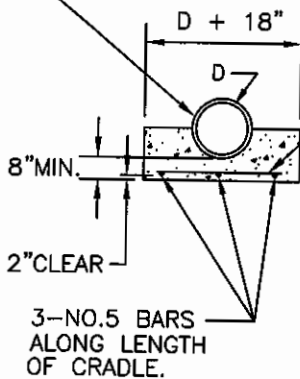

SECTION B-B

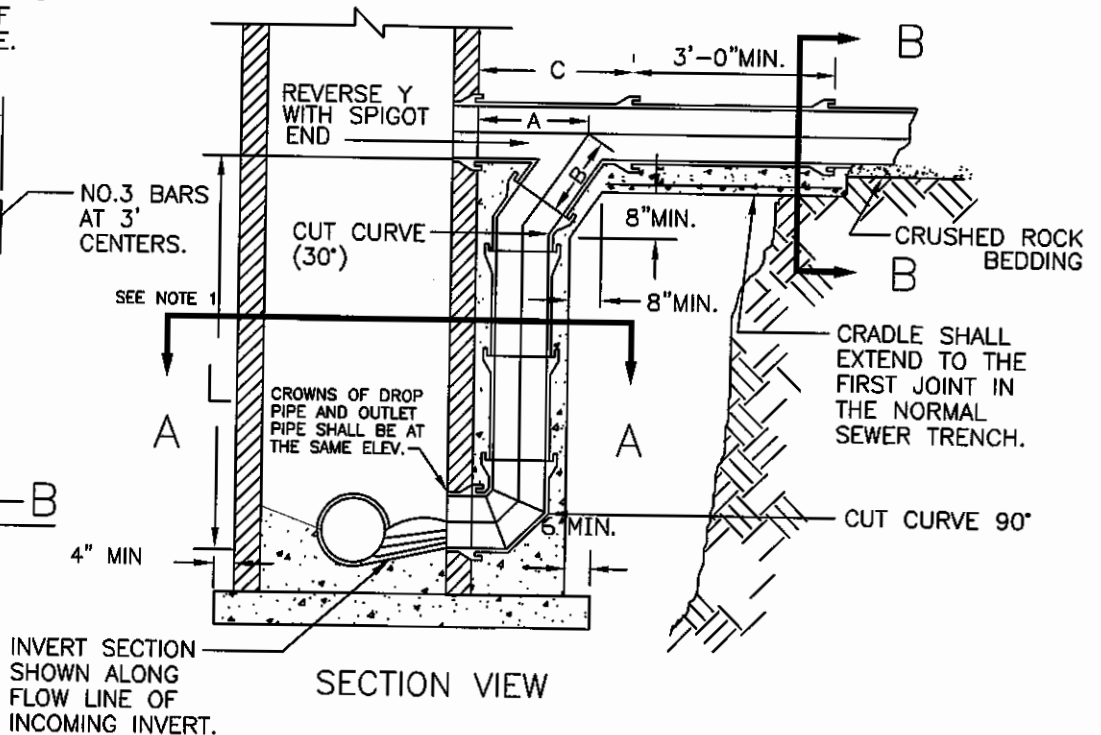

NOTE 1:
L > 2' DROP REQUIRES
DROP MANHOLE.

Engineering Department
City of Raymore
100 Municipal Circle
Raymore, MO 64083
816-331-1852 Fax 816-331-8067

DRAWN
Modified 2013

CHECKED

APPROVED

CITY OF RAYMORE

MANHOLE- OUTSIDE DROP
USE WITH ANY STANDARD MANHOLE

SIZE A	FSCM NO.	DWG NO. San - 3	REV
-----------	----------	--------------------	-----

SCALE NONE

SHEET 1 OF 1

PICK HOLES SHALL BE PROVIDED IN EACH COVER.

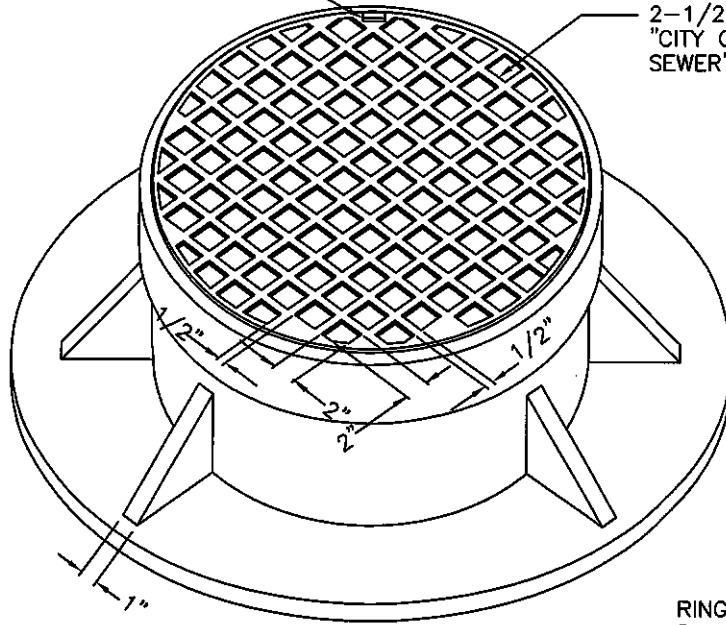

2-1/2" BLOCK LETTERING
"CITY OF RAYMORE
SEWER" This is the only
lettering allowed.

MATERIAL TO MEET
SPECIFICATIONS FOR
GRAY IRON CASTINGS
ASTM DESIGNATION
A-48, CLASS 25 AS
A MINIMUM
REQUIREMENT.

RING AND COVER SHALL BE
PAINTED WITH A MINIMUM OF
ONE COAT OF ASPHALT BASE
PAINT.

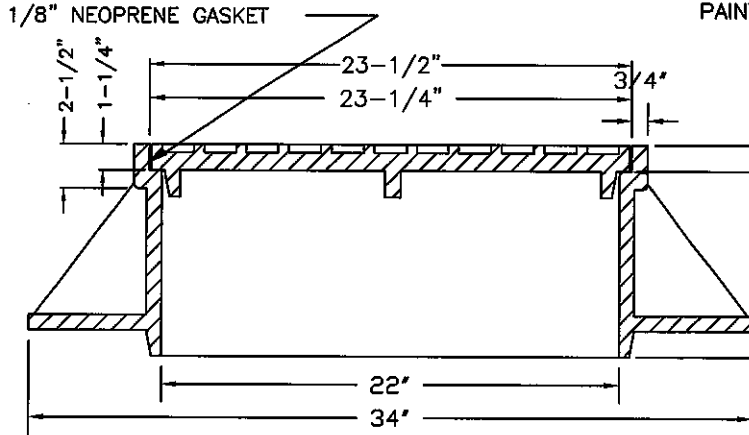

SURFACES BETWEEN
RING AND COVER
SHALL BE MACHINED
TO PROVIDE A TRUE
PLANE AROUND THE
ENTIRE BEARING
AREA OF THE
COVER.

MINIMUM WEIGHT COVER-
160 LBS.
MINIMUM WEIGHT RING-
240 LBS.
See specs for approved castings.

Engineering Department City of Raymore 100 Municipal Circle Raymore, MO 64083 816-331-1852 Fax 816-331-8067	
DRAWN Modified 2013	DATE
CHECKED	
APPROVED	

CITY OF RAYMORE

MANHOLE RING & COVER (CASTING)

SIZE A	FSCM NO.	DWG NO. San - 4	REV
SCALE NONE	SHEET 1 OF 1		

TWO PICK HOLES SHALL BE PROVIDED IN EACH COVER.

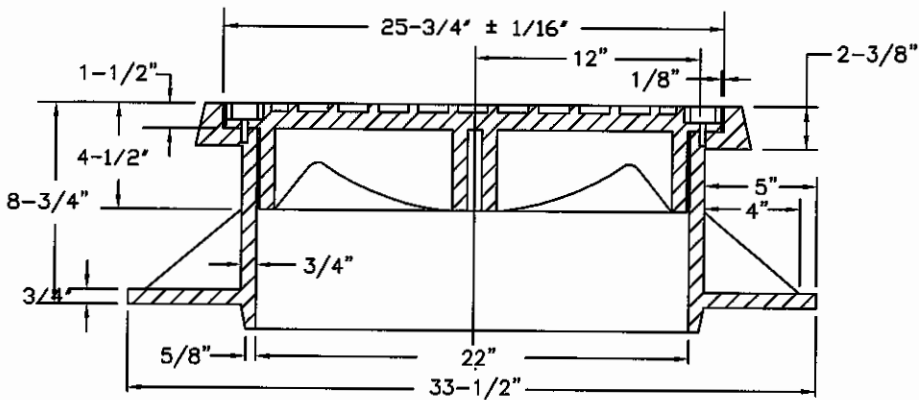
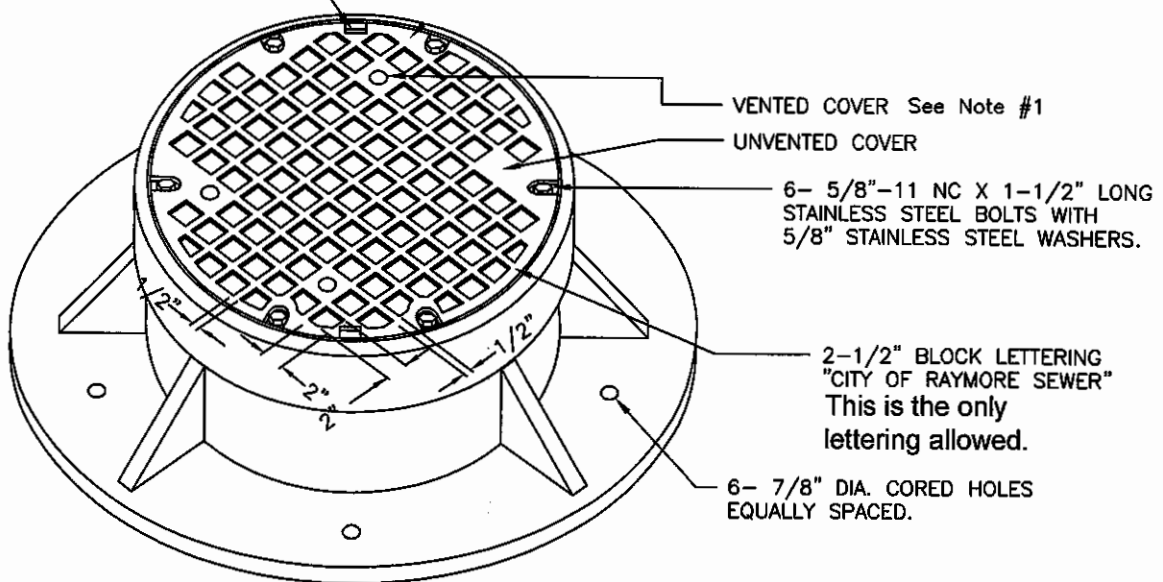

1/8" NEOPRENE GASKET MAY BE USED.

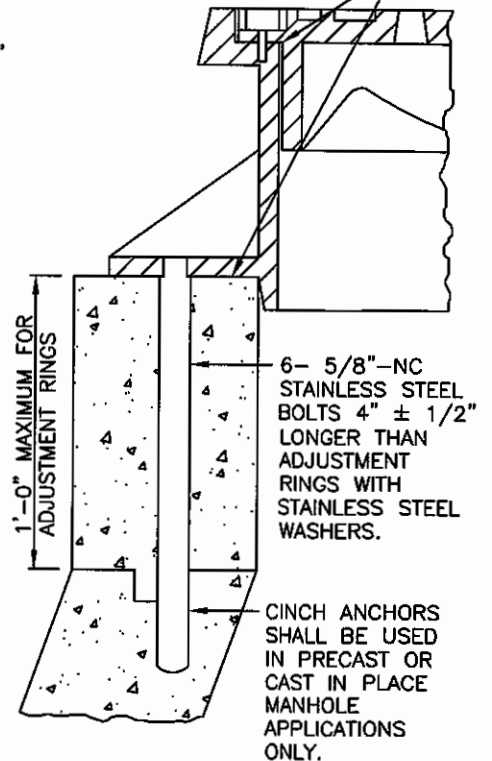

NOTES:

1. VENTED COVER SHALL HAVE FOUR VENT HOLES AS INDICATED.
2. FOR PRESSURE APPLICATIONS CONSULT THE ENGINEER.
3. MATERIAL TO MEET SPECIFICATIONS FOR GREY IRON CASTINGS ASTM DESIGNATION A-48, CLASS 25 AS A MINIMUM REQUIREMENT. DESIGNATION A-48, CLASS 25 AS A
4. SURFACES BETWEEN RING AND COVER SHALL BE MACHINED TO PROVIDE A TRUE PLANE AROUND THE ENTIRE BEARING AREA OF THE COVER.
5. RING AND COVER SHALL BE PAINTED WITH AN ASPHALT BASE PAINT.

MINIMUM WEIGHT COVER-
190 LBS.
MINIMUM WEIGHT RING-
250 LBS.
See specs for
approved castings.

Engineering Department
City of Raymore
100 Municipal Circle
Raymore, MO 64083
816-331-1852 Fax 816-331-8067

DRAWN	Modified 2013
CHECKED	
APPROVED	

CITY OF RAYMORE
BOLTED MANHOLE RING & COVER
SOLID & VENTED

SIZE	FSCM NO.	DWG NO.	REV
A		San - 5	
SCALE NONE		SHEET 1 OF 1	

**
 EMBED NO. 9 WIRE (2 PER JOINT)
 IN BASE OF ENCASEMENT TO TIE
 DOWN PIPE TO PREVENT FLOATING.

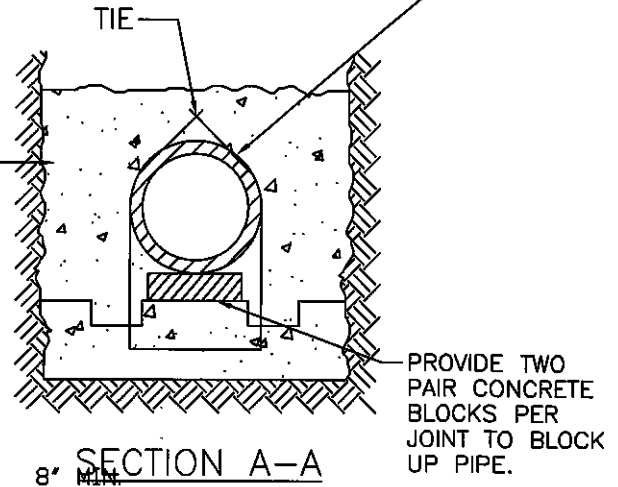
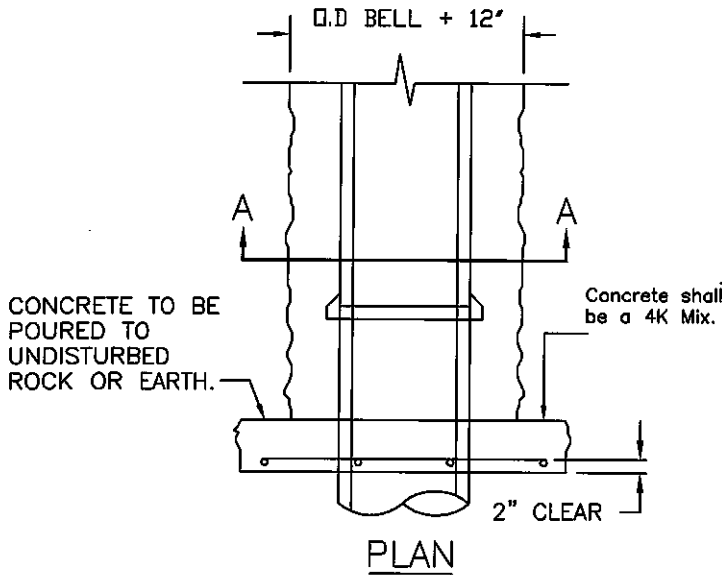

SECTION A-A

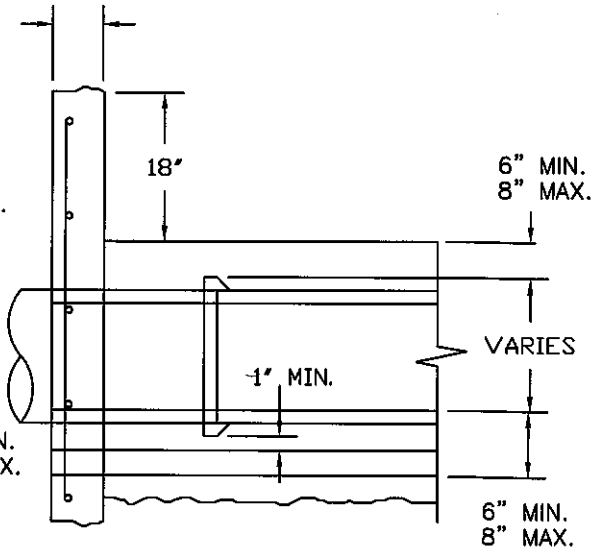
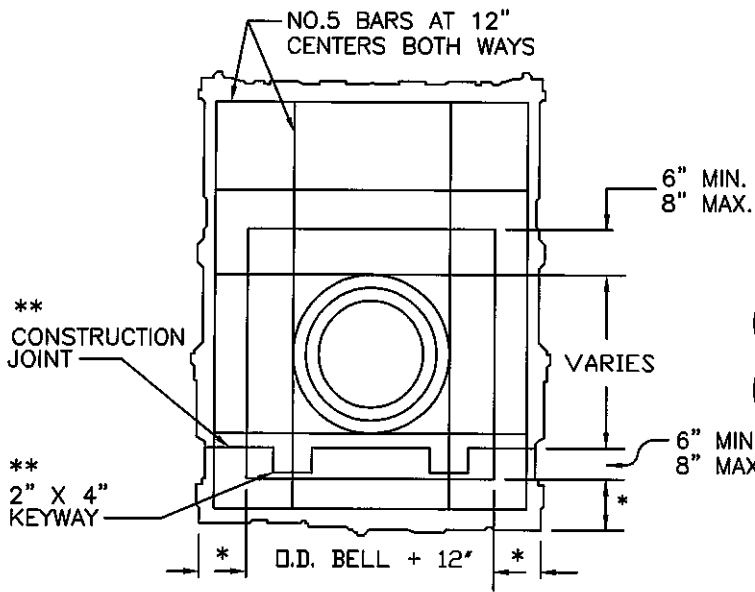

SIDE ELEVATION

* 6" FOR TRENCH IN ROCK
 12" FOR TRENCH IN EARTH

ELEVATION

** APPLIES IF POUR IS NOT MADE MONOLITHICALLY.

NOTE:
 ALL CONCRETE ENCASEMENT
 IN ROCK SHALL BE POURED
 AGAINST THE FACE OF ROCK
 ON BOTH SIDES AND BOTTOM
 OF TRENCH WHEN USING
 MONOLITHIC POUR. PIPE
 SHALL BE ANCHORED TO
 PREVENT FLOATING OR
 DISPLACEMENT OF THE PIPE.

Estimated concrete quantities. Concrete to be poured full width of trench.

PIPE SIZE	CU.YDS./LIN.FT.	PIPE SIZE	CU.YDS./LIN.FT.
8"	.1173	15"	.2063
10"	.1397	18"	.2533
12"	.1647	21"	.3056

Engineering Department
 City of Raymore
 100 Municipal Circle
 Raymore, MO 64083
 816-331-1852 Fax 816-331-8067

CITY OF RAYMORE

PIPE ENCASEMENT
 AND COLLAR

DRAWN
 Modified 2013

DATE

CHECKED

SIZE

FSCM NO.

DWG NO.

San - 6

REV

APPROVED

SCALE NONE

SHEET 1 OF 1

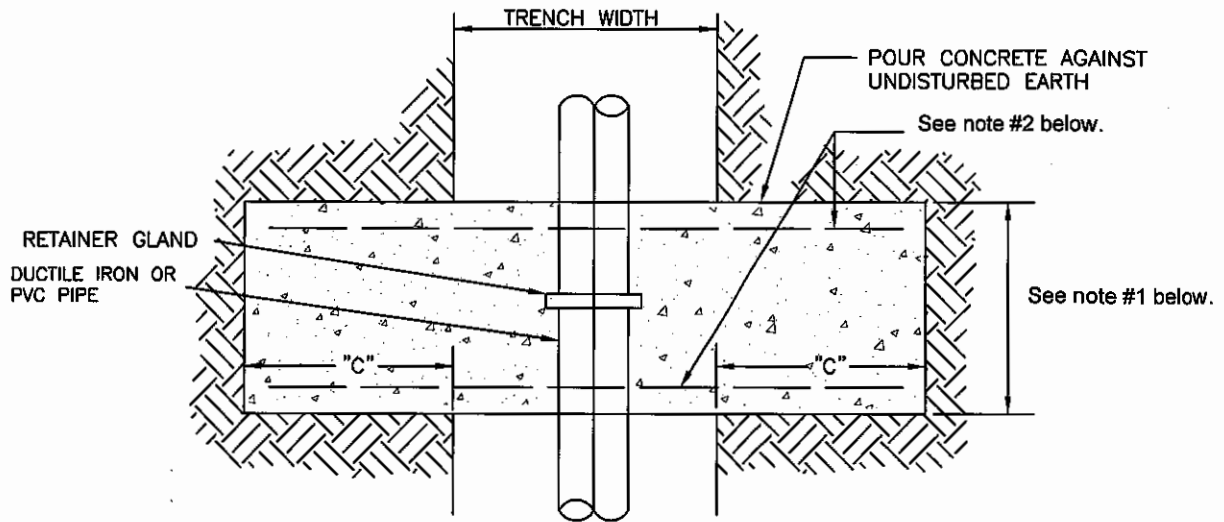

PLAN

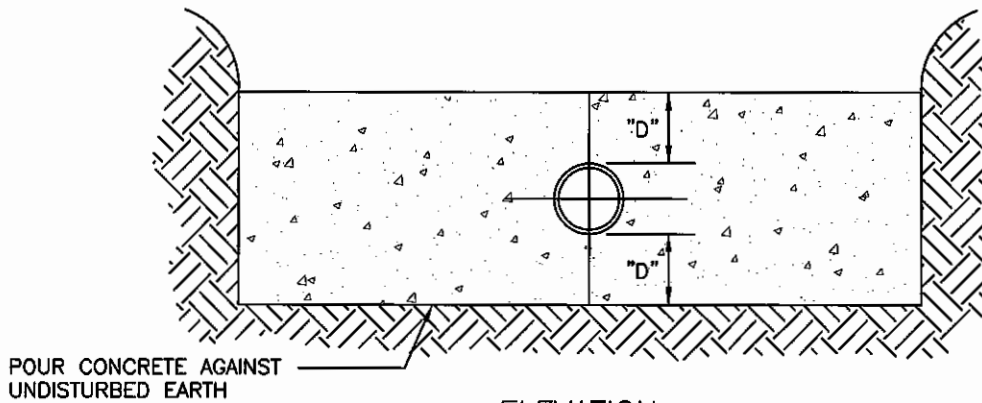

ELEVATION

PIPE SIZE	"D" MIN.	CU. FT.	"C"
2"	4"	12	24
6"	4"	18	24
8"	7"	30	24
12"	15"	61	24
16"	18"	-	30
20"	20"	-	42
24"	24"	-	48

1. For 2 through 12 inch pipe, 24 inch minimum or equal to trench width. For 16 through 24 inch pipe, 18 inch minimum or equal to trench width.
2. #5 rebars at 12 inch centers in each direction for 16 through 24 inch pipes.
3. Concrete shall have a minimum strength of 4000 PSI.

Engineering Department
 City of Raymore
 100 Municipal Circle
 Raymore, MO 64083
 816-331-1852 Fax 816-331-8067

DRAWN
 Modified 2013

CHECKED

APPROVED

CITY OF RAYMORE

TYPICAL STRADDLE BLOCK

SIZE
 A

FSCM NO.

DWG NO.

San - 7

REV

SCALE NONE

SHEET 1 OF 1

EARTH OR EARTH AND ROCK OR OTHER SUITABLE MATERIAL. ROCK SHALL NOT EXCEED 305mm(12") IN ITS LONGEST DIMENSION.

Clean stone bedding/backfill shall extend 6" above the pipe, full width of trench.

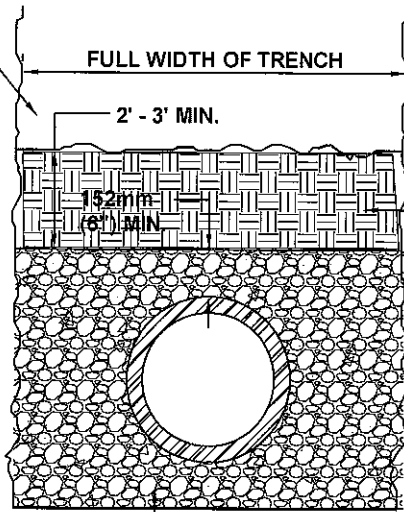

EARTHEN BACKFILL

51mm(2") BELOW THE PIPE BELL OR 102mm(4") BELOW THE PIPE BARREL. WHICHEVER IS GREATER.

CRUSHED CLEAN STONE BEDDING @10mm (3/8") MAXIMUM SIZE

PIPE BEDDING

COMPLETE BEDDING OF CRADLED PIPE AS SHOWN ABOVE IN "PIPE BEDDING".

CONCRETE CRADLE QUANTITY

Pipe Size	Cu. Yds./Ft
8"	.032
10"	.038
12"	.043
15"	.057
18"	.076
21"	.097
24"	.120

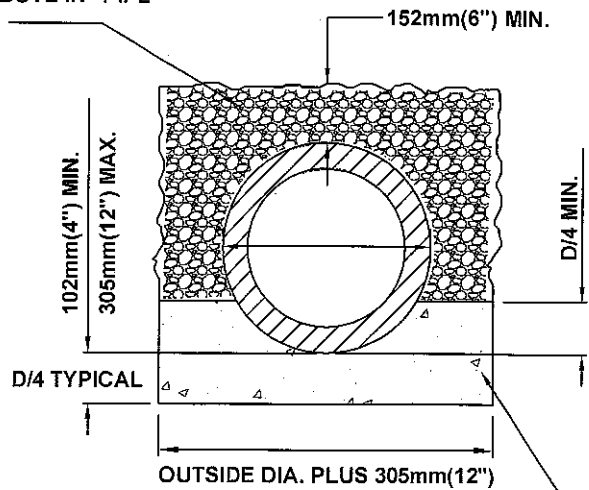

CONCRETE SHALL BE 4K MIX

CONCRETE CRADLE

Engineering Department City of Raymore 100 Municipal Circle Raymore, MO 64083 816-331-1852 Fax 816-331-8067		CITY OF RAYMORE			
DRAWN Modified 2013	DATE			PIPE BEDDING & CRADLE FOR SANITARY SEWER PIPE	
CHECKED		SIZE A	FSCM NO.	DWG NO. San - 8	REV
APPROVED		SCALE NONE		SHEET 1	OF 1

Engineering Department City of Raymore 100 Municipal Circle Raymore, MO 64083 816-331-1852 Fax 816-331-8067		CITY OF RAYMORE			
DRAWN Modified 2013	DATE			PIPE BEDDING & CRADLE FOR SANITARY SEWER PIPE	
CHECKED		SIZE A	FSCM NO.	DWG NO. San - 8	REV
APPROVED		SCALE NONE		SHEET 1	OF 1